

E·VALUE

電動車專用AC充電設備
電動車交流充電器
完整操作指引手冊

ELECTRIC VEHICLE AC CHARGER
WALL-MOUNT EV CHARGER
OPERATING INSTRUCTION MANUAL

目錄

1. 關於本《操作手冊》	2	6. 操作說明	28
錯誤或疏漏	3	待機畫面	29
版權與商標	3	充電開始前	30
2. 安全資訊	4	充電開始	31
重要安全說明	5	充電結束	32
警告	5	充電完成	33
注意事項	5	7. 系統設定	34
3. 規格	6	8. 疑難排除 Q&A	54
產品外觀	7	9. 充電器有限品質保養	58
產品規格	8	一般條款	59
功能	9	責任限制	59
4. 準備安裝	12	保養	59
最低要求	13		
供電電線	13		
供電方式	13		
確定無熔絲開關額定容量	13		
充電器選擇最佳位置	13		
漏電保護斷路器的選擇	13		
有關安裝的注意事項	13		
檢查內容物	14		
5. 充電器安裝步驟	16		
工具及材料	17		
壁掛式充電器安裝步驟	18		
電纜線配線準備	21		
電纜線配線	22		
確認需求電流及檢測	24		
通電檢測及組裝	25		
接線圖	26		

關於本《操作手冊》

01

錯誤或疏漏

如對本《操作手冊》欲傳達任何建議或疏漏之處，歡迎您將意見或建議，傳送電子郵件至：service@f-evalue.com

版權與商標

本《操作手冊》中所有資訊，均受華城電能著作權及其他知識產權法保護。
若事先未獲得華城電能書面許可，則不得對資料中的全部或部分內容進行修改、重現或複製。

產品規格如有變更，恕不另行通知。

安全資訊

02

重要安全說明

本《操作手冊》包含安裝及維護壁掛式交流充電器時必須遵循的重要指示與警告。

警告

- 使用本產品前，請先閱讀所有指示。
- 使用本產品時如附近有兒童的情況下，需監督控管兒童並留意安全。
- 充電器必須藉由永久性配線系統或保護接地導體來做接地。
- 請勿在具易燃性、易爆性、刺激性或可燃性物質、化學物品或氣體附近安裝或使用充電器。
- 安裝或清潔充電器之前，請先關閉斷路器上的輸入電源。
- 請嚴格遵循所指定的工作參數使用充電器。
- 請勿將水或任何其他液體直接噴灑安裝在牆上的開關箱。請勿將任何液體噴灑充電槍或將充電槍浸入液體中。請將充電槍放在基座上，以防止接觸不必要的汙染物或濕氣。
- 如果充電器存在缺陷、出現裂痕、磨損、破裂或損壞以致無法使用或操作，請停止使用。
- 請勿試圖拆卸、維修、不當調整或改裝充電器。使用者切勿自行維修充電器。如果需要任何維修或修改，請聯絡華城電能科技股份有限公司。
- 運送充電器時，請務必小心。請勿讓充電器承受強大作用力或衝擊力，或拉動、扭曲、纏結、拖曳或踩踏充電器，以防止機體或任何元件受損。
- 請勿用手指或尖銳金屬物件（例如電線、工具、或針...等）接觸充電槍頭的末端。
- 請勿用力折疊充電器的任何零件或對其施加壓力，或者使用尖銳的物件破壞。
- 請勿將異物插入充電器的任何部位。
- 使用充電器可能會影響或損壞醫療或植入式電子設備的運作，例如植入式心臟起搏器或植入式心臟除顫器。使用充電器之前，請就充電對此類電子設備的影響向電子設備製造商進行諮詢。

注意事項

- 請勿以發電機作為充電電源。
- 錯誤安裝及測試充電器將對車輛電池及 / 或充電器本身帶來潛在損壞。由此導致的任何損壞均不屬於保固範圍。
- 請勿在充電器工作範圍 -13° F 至 122° F (-25° C 至 50° C) 以外的溫度下操作充電器。
- 若有用到網路線，長度不得超過三十公尺。
- 本充電設備需搭配合格認證之無熔絲開關過載保護器和漏電保護斷路器同時使用方可符合國家 BSMI 之 VPC (Voluntary Product Certification; 自願性產品驗證) 認證規定，安裝上若有問題請與華城聯繫諮詢或購買合格料件，若非使用合格認證之無熔絲開關過載保護器和漏電保護斷路器，造成本充電設備異常或出現其他問題由使用者自行負責。
- 禁止使用轉接器或轉換轉接器。
- 禁止使用延長線組。

1. 產品外觀

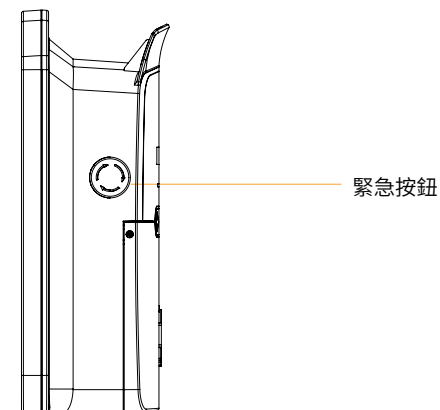
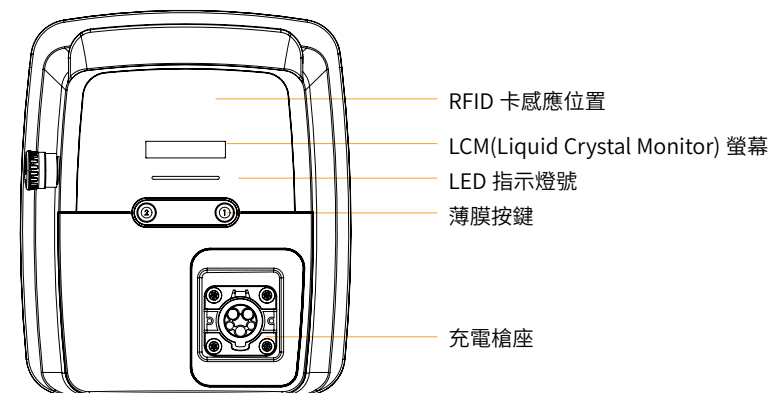

規格

03

2. 產品規格

說明	規格
電壓規格	<ul style="list-style-type: none"> 使用電壓：220V 單相交流電：L、中性線與地線 電壓範圍：N 端與 L 端之間 220V 交流電
頻率範圍	60 Hz
輸出電流	CBDA-X32B：(最高)32A CBDA-X50A：(最高)50A CBDA-X70B：(最高)70A CBDA-X80A：(最高)80A
輸出功率	CBDA-X32B：(最高)7.04KW CBDA-X50A：(最高)11KW CBDA-X70B：(最高)15.4KW CBDA-X80A：(最高)17.6KW
充電槍規格	CBDA-X32B、CBDA-X70B：IEC 62196 CBDA-X50A、CBDA-X80A：SAE J1772
電纜線長	5 米
充電器外觀尺寸	長度：393.8 毫米 / 寬度：338.54 毫米 / 高度：144.53 毫米
重量 (包含充電槍線)	CBDA-X32B：7.9 公斤 CBDA-X50A：9.2 公斤 CBDA-X70B：10.4 公斤 CBDA-X80A：10.5 公斤
按鈕	緊急停止開關、功能鍵①、功能鍵②
指示燈號	待機：綠燈 / 充電中：藍燈 / 充電飽：閃綠燈 / 錯誤：紅燈
使用者身份辨識	RFID 讀卡機 (註：可選擇啟用或關閉身分辨識功能)
LCM 液晶顯示	中英文顯示
保護功能	過電壓保護、低電壓保護、過電流保護、短路保護、漏電保護、過載保護、過溫保護
操作溫度	-25°C 至 50°C
濕度	<95% 相對溼度
IP 防塵防水等級	IP55
認證規範	CNS15511

(註：完整系列機種規格請查 P62)

3. 功能

(1) 可選輸出額定電流

a. CBDA-X32B 機型

根據現地需求調整額定電流的輸出。可調整充電器的電流範圍為 6、16、24 或 32A。

b. CBDA-X50A 機型

根據現地需求調整額定電流的輸出。可調整充電器的電流範圍為 6、16、24、32、或 50A。

c. CBDA-X70B 機型

根據現地需求調整額定電流的輸出。可調整充電器的電流範圍為 6、16、24、32、50 或 70A。

d. CBDA-X80A 機型

根據現地需求調整額定電流的輸出。可調整充電器的電流範圍為 6、16、24、32、50、70 或 80A。

(註：需於安裝時調整，安裝完成若尚須調整，需請有合格證照的專業電工人員評估和設定。)

(註 2：完整系列機種規格請查 P62)

(2) 延遲充電啟動

若想延遲充電啟動時間，可按下功能鍵②即可預設 1、2、4 或 8 小時後，開始充電。

例：現在時間是 10:00，希望在 2 小時後開始充電，所以按功能鍵②兩次，倒數 2 小時完畢之後，充電器即會自動啟動充電功能。(註：與車端的充電接口需保持正確連接)

(3) 加卡 / 刪卡

· 加卡 (一次只能加入一張卡號)：

a. 按下緊急按鈕，LED 燈轉為紅燈。

b. 長按功能鍵①，聽到嗶嗶兩聲即可以放開，此時藍 / 綠燈交錯閃爍，進入加卡模式 (螢幕顯示文字請忽略)

c. 將卡片靠近 RFID 讀卡位置，嗶長音後，會回到紅燈狀態，代表已加入卡號。

d. 復歸緊急按鈕，LED 燈轉為綠燈，充電樁待機中。

· 刪卡 (所有卡號全部刪除)：

a. 按下緊急按鈕，LED 燈轉為紅燈。

- b. 長按功能鍵①，聽到嗶嗶兩聲即可以放開，此時藍 / 綠燈交錯閃爍，進入加卡模式（螢幕顯示文字請忽略）
- c. 短按功能鍵②，此時藍 / 紅燈交錯閃爍，代表進入刪卡模式（螢幕顯示文字請忽略）
- d. 進入刪卡模式後，長按功能鍵①，直到嗶長音，再放開按鍵，會回到紅燈狀態，代表已刪除全部卡號。
- e. 復歸緊急按鈕，LED 燈轉為綠燈，充電樁待機中

(4) 恢復原廠設定（OCPP 模式除外）

- a. 按下緊急按鈕，LED 燈轉為紅燈。
- b. 長按功能鍵①，聽到嗶嗶兩聲即可以放開，此時藍 / 綠燈交錯閃爍，代表進入加卡模式（螢幕顯示文字請忽略）
- c. 短按功能鍵②，此時藍 / 紅燈交錯閃爍，代表進入刪卡模式（螢幕顯示文字請忽略）
- d. 短按功能鍵②，此時綠 / 紅燈交錯閃爍，代表進入恢復原廠設定模式後（螢幕顯示文字請忽略）
- e. 長按功能鍵①，此時 LED 閃白燈，再次長按功能鍵①確認恢復原廠設定，此時 LED 閃紫燈代表已恢復原廠設定值
- e. 復歸緊急按鈕，此時充電樁準備重新啟動，螢幕顯示【設備開機中 ...】LED 燈將由紅燈轉為白燈，請等待開機（大約 3 分鐘）
- f. LED 燈轉為綠燈，充電樁待機中

準備安裝

04

1. 最低要求

- 量測電力供應負載，確認可滿足充電器最大之電流。
- 開關箱內備用或新增之無熔絲開關額定電流需大於充電器最大電流 1.25 倍。
- 確認現場電壓及配線之距離，計算電壓之壓降是否符合當地法令或充電器之最小需求。
- 請於充電器前方預留斷路器及配管配線至車位後方 1.2M 高位置，出線預留 0.5M 線長，以利結線。

2. 供電電線

- 電纜線需使用當地國家認證合格之絕緣披覆銅導線，且導線之耐電流須大於無熔絲開關之額定電流 1.25 倍以上。(依台電電工法規標準)
- 在選擇連接電纜時，請考慮可能的縮減係數和充電內部連接區域內升高的環境溫度。在特定情況下，這可能要求增大電纜截面以及調整連接電纜的耐溫性。

3. 供電方式

本充電器使用電力為單相三線 220V，可兼容三相四線 220V/380V、單相三線 110V/220V、單相二線 220V、三相三線 220V。(注意：電力配接建議由合格電力技術員或技師進行配接，避免發生人員觸電或短路意外)。

4. 確定您的無熔絲開關額定容量

- 確定您的總開關規格，請檢查配電盤或開關箱，以確定安裝場地的電力來源可用電流量。
- 選擇過電流保護開關時，應評估開關櫃內因環境溫度上升所帶來的影響。特定情況下，可能需調低充電電流設定，以確保系統的穩定與可用性。額定電流應依據實際充電需求、可供使用的連接功率及設備銘牌資訊進行設定。· 此過電流保護裝置須符合 CNS 14816-2、IEC 60947-6-2、IEC 61009-1，或 CNS 14985 系列及 IEC 60269 系列等相關標準。
- 充電器內有內置旋轉開關，供您調整其工作電流。備用或新增的無熔絲開關額定電流選用應按以下數值的連續電流值 6、16、24、32A 選擇適當之無熔絲開關。
 - a. CBDA-X32B 機型：根據現地需求調整額定電流的輸出。可調整充電器的電流範圍為 6、16、24 或 32A。
 - b. CBDA-X50A 機型：根據現地需求調整額定電流的輸出。可調整充電器的電流範圍為 6、16、24、32 或 50A。
 - c. CBDA-X70B 機型：根據現地需求調整額定電流的輸出。可調整充電器的電流範圍為 6、16、24、32、50A 或 70A。
 - d. CBDA-X80A 機型：根據現地需求調整額定電流的輸出。可調整充電器的電流範圍為 6、16、24、32、50A、70A 或 80A。

(註：完整系列機種規格請查 P62)

5. 漏電保護斷路器的選擇

連接電纜必須安裝於符合國家法律規範的建築設施內，並遵循相關法令要求。

應注意：

- 每台充電樁都必須通過獨立的漏電保護斷路器進行連接。且該斷路器不得與其他電路共用。
- 在台灣地區，必須加裝 TYPE B RCCB，或 EV 型的 TYPE A RCCB，且其額定電流需大於充電樁的額定電流。所使用的漏電保護斷路器應符合下列任一標準：IEC 61008-1、IEC 61009-1、CNS 14816-2 或 IEC 62423。

6. 壁掛式交流充電器選擇最佳位置

安裝位置應確保充電電纜可連到車端的充電接口，充電器應該位於以下位置：

- (1) 在封閉式車庫內，一般位於車輛充電口旁。
- (2) 通風良好的地方，避免安裝在封閉式箱體內或傳熱裝置附近。
- (3) 室內充電器安裝需在離地 100 公分以上，不超過 120 公分的位置。
- (4) 室外充電器安裝需在離地 100 公分以上，不超過 120 公分的位置。
- (5) 充電器本體需離週遭障礙物 20 公分以上，以便電纜線存放時纏繞於充電器本體。

7. 有關安裝的注意事項

- 安裝前請確認供電端開關已關閉斷電，並作好預防性防護，避免充電器安裝過程發生人員觸電危害。
- 配管線過程需依當地電力相關法規進行安裝。
- 充電樁本身沒有電源開關。故障電流斷路器或家用安裝的斷路器可用作電源隔離開關。

8. 檢查內容物

項目	說明	數量
1	充電器本體和槍線	1
2	壁掛架	1
3	壁掛鐵件	2
4	壁掛件用皿頭螺絲 (M3 X 8L)	8
5	壁掛架和電纜掛鉤圓頭螺絲 (M4 X 12L)	5
6	充電槍電纜線掛鉤	1
7	端子台蓋板	1

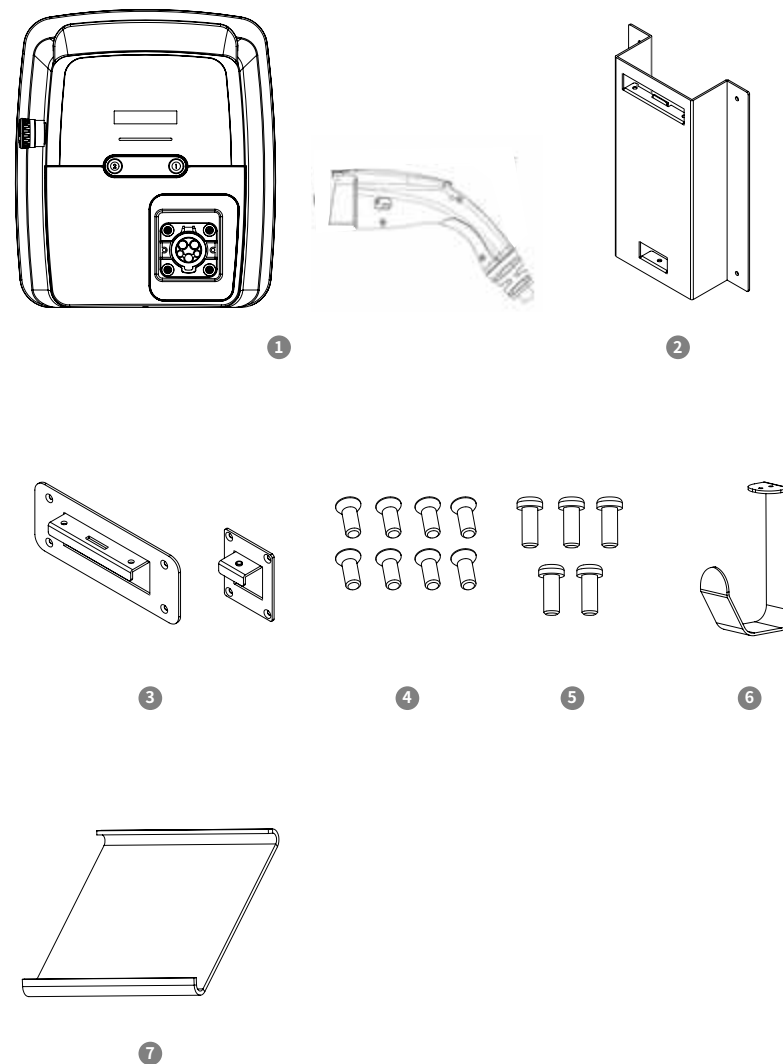

充電器安裝步驟

05

1. 工具及材料

- 鉛筆或簽字筆
- 電工鉗
- 剝線鉗
- 2mm²~14mm² 壓接鉗
- 捲尺
- 三用電表或數位萬用電表
- 十字螺絲起子
- 小型平頭螺絲起子
- 水平儀
- 電鑽及鑽頭
- 塑膠壁虎
- 圓型端子 R8-6
- 扭力起子

2. 壁掛式充電器安裝步驟

- (1) 使用支架作為指引，在安裝牆面上標記鑽孔位置
- 使用 5.8mm 水泥鑽頭鑽孔，並將 2 分塑膠壁虎埋入孔中。
 - 使用螺絲將壁掛架（注意壁掛架方向）鎖固於牆面。

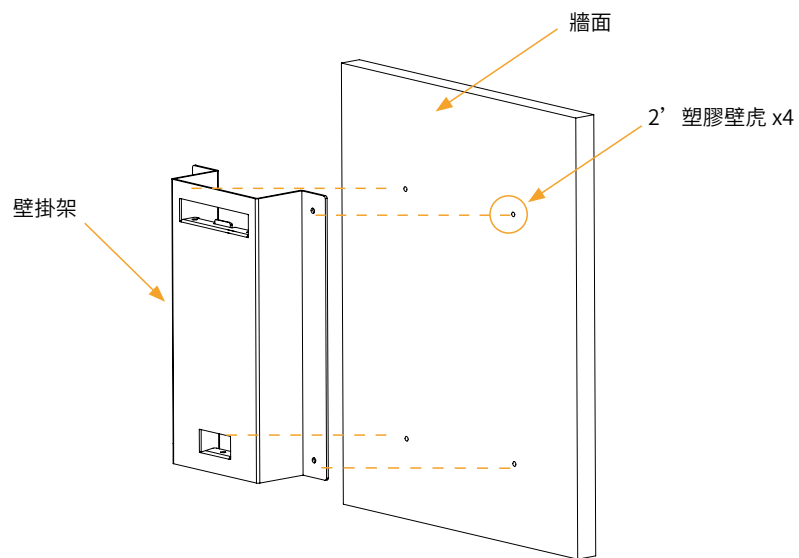

(2) 壁掛架掛勾及電纜線掛勾組裝

- 使用附件螺絲包中的 M3 皿頭螺絲將壁掛架上掛勾與下掛勾固定於充電器背板。
- 使用附件螺絲包中的 M4 圓頭螺絲將充電槍電纜線掛勾固定於充電器左下方。

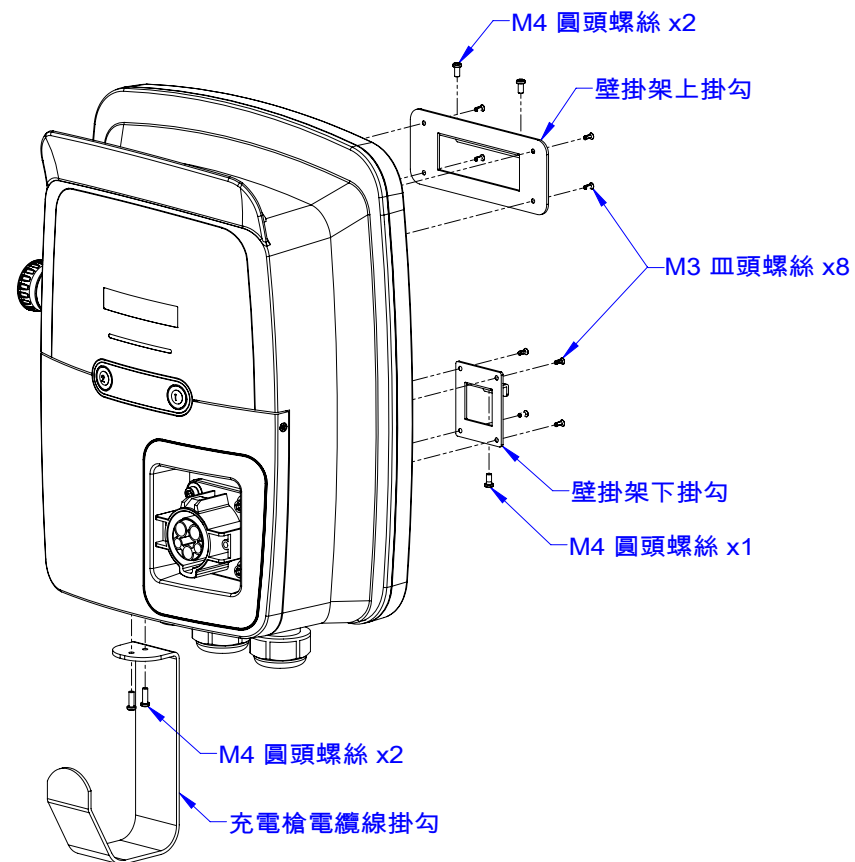

(3) 將充電器本體掛到固定在牆面上的支架，並使用附件螺絲包中的 M4 圓頭螺絲將上掛勾與支架固定。

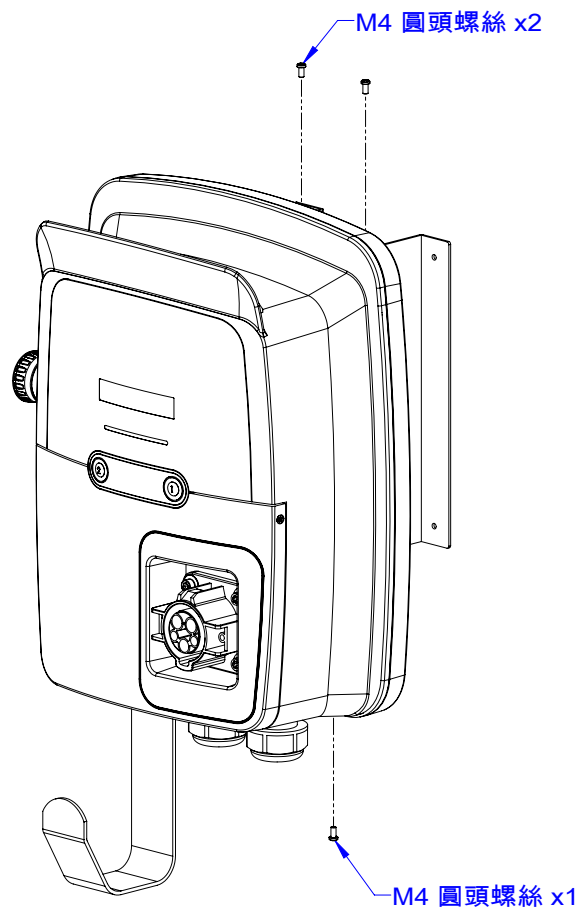

3. 電纜線配線準備

(1) 使用十字螺絲起子將充電器外蓋殼及內密封板卸除。

- 小心將外蓋殼左右及下方的十字皿頭螺絲卸除，並取下外蓋。
- 小心將內密封板正面四個角落的十字圓頭螺絲卸除，並取下密封板。

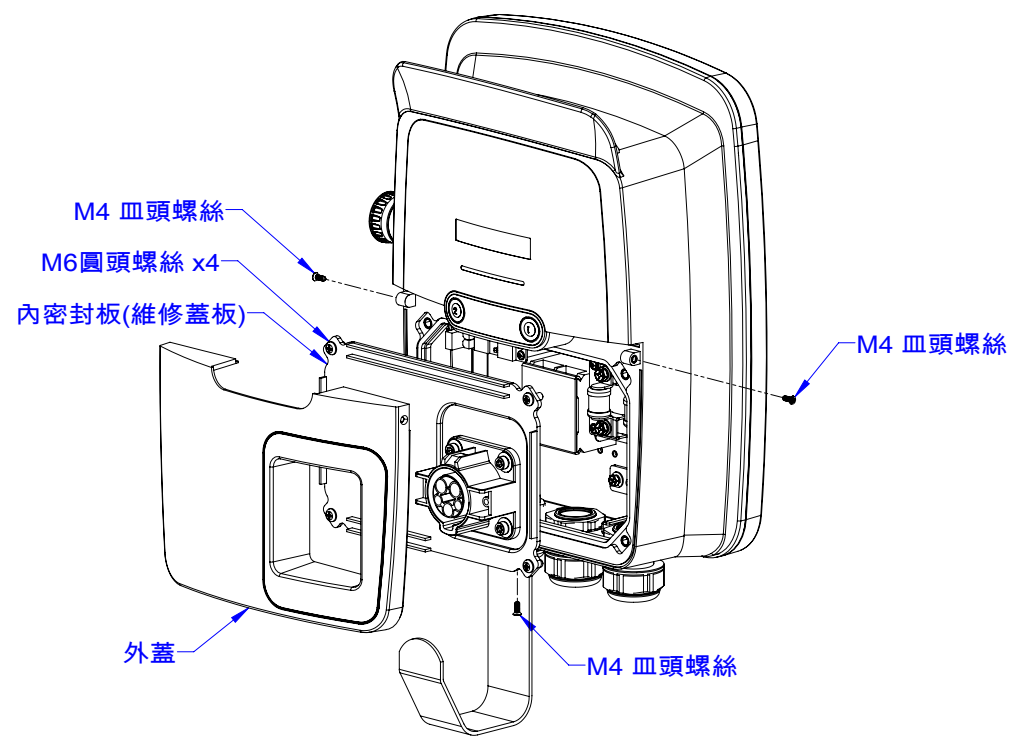

4. 電纜線配線

(1) 移除端子座上的透明保護蓋，將電纜線由充電器本體下方的電纜固定頭進線，並將電纜線固定於端子台上。

- a. 逆時針旋轉鬆開進線口的電纜固定頭，將電纜線穿入約 10~15cm 後順時針旋轉鎖緊電纜固定頭，並稍微拉扯確認電纜線不會移動。
- b. 將電纜線的 L1、L2 與接地電線分別壓接圓型端子後使用扭力起子鎖附於端子台上的 Lin、Nin 與 GND 上 (4N·m)，並將端子座透明保護蓋裝回。(注意：L1、L2 與接地電線的線色需依各國家或地區法規標示。)

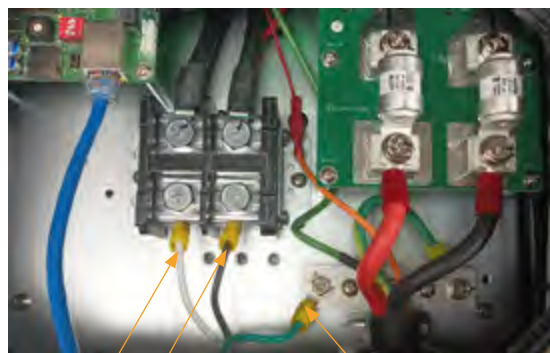
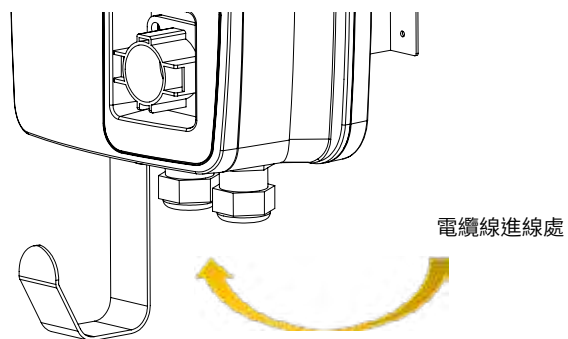

火線 火線或中性線 接地線

充電器本體內端子台

5. 使用模式設定

壁掛式充電器，可依需求調整使用模式，相關指撥開關設定方式如下；

注意：場勘時請先確認設備使用模式需求及有無額外購買 RFID 感應卡需求。

	隨插即用 (預設值)
	RFID 卡片認證
	OCP (註：此功能只限 OCPP 後台主機連線用)
	全卡
	系統設定模式 (如有 EMS 或自有後台串接需求請使用此設定)

8. 接線圖

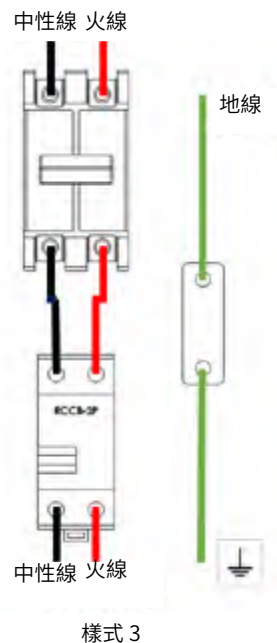
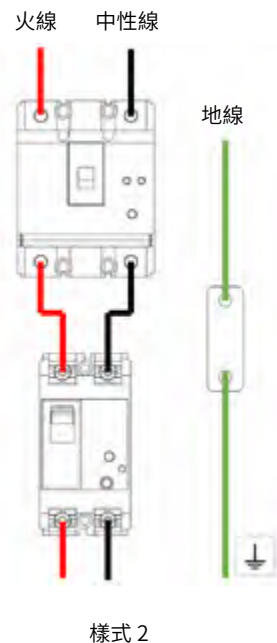
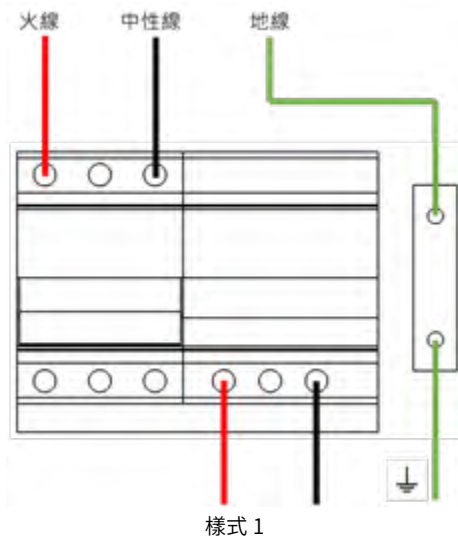

操作說明

06

1. 待機畫面

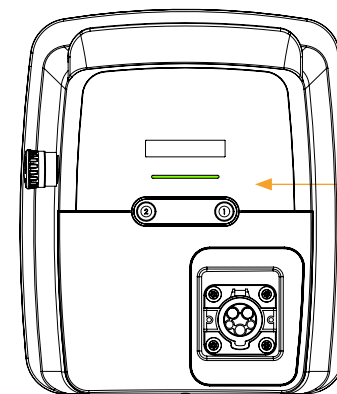

Charger Standby
充電器待機中

注意事項：

- (1) 本設備僅限電動汽車使用。
- (2) 充電中請勿強行拔除充電槍。
- (3) 如遇大雨造成雨水落在充電槍接口，請先將水珠擦拭乾淨再行使用。
- (4) 充電過程如發生緊急狀況，請按左側紅色緊急按鈕，立即停止充電。如：人員觸電、車端異常等。
- (5) 使用過程如有任何問題，請撥打華城電能科技股份有限公司 02-2325-3320。

2. 充電開始前

- 充電前原始設定為 0 小時，當按下功能鍵②可預設 1、2、4 或 8 小時後，開始充電。當按到 8 小時後，再多按一次就變回原始設定。
- 功能鍵②設定必須在待機中（綠燈），才能設定。如要取消必須按功能鍵②回到原始設定。

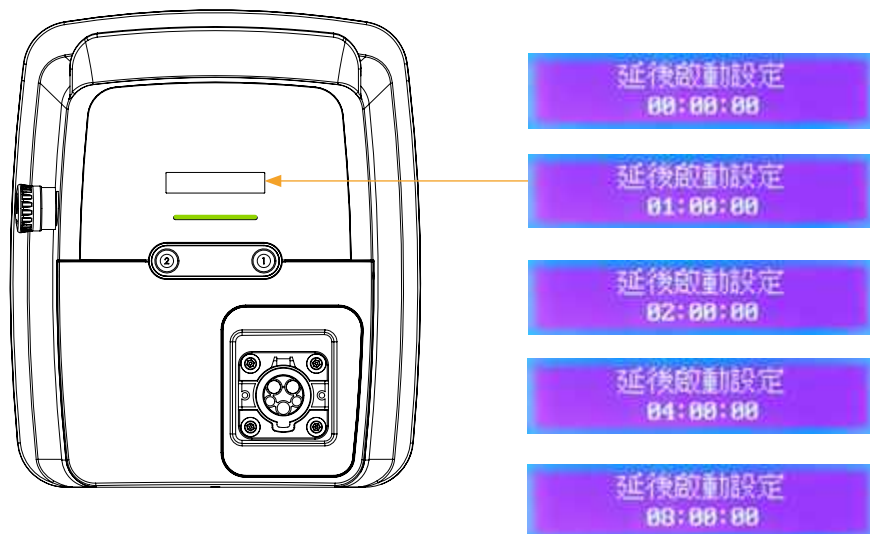

3. 充電開始

- 取下充電槍連接至電動車充電接口。
- 進行充電時，指示燈號由恆亮綠燈轉為恆亮藍燈。
- 供電中時，LCM 輪流以中英文顯示當前電壓、電流及已用電量。

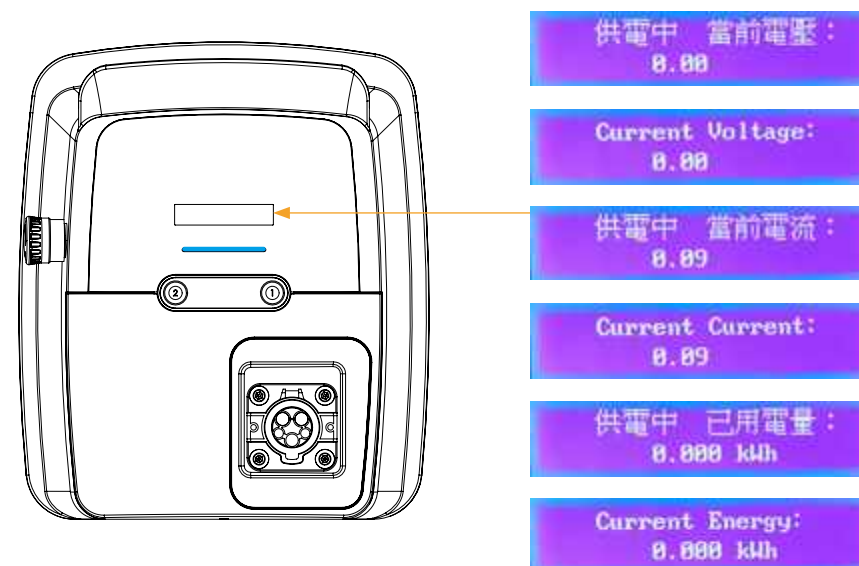

4. 充電結束

- 完成充電時，指示燈號由恆亮藍燈轉為閃爍綠燈。
- LCM 輪流以中英文顯示使用電量及時間。

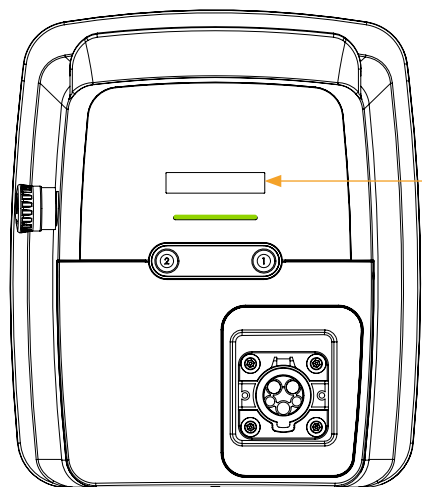

使用電量：
0.000 kWh

Used Energy:
0.000 kWh

使用時間：
00:00:40

Duration:
00:00:40

5. 充電完成

將充電槍取出放回充電插座，指示燈號由閃爍綠燈轉為恆亮綠燈。

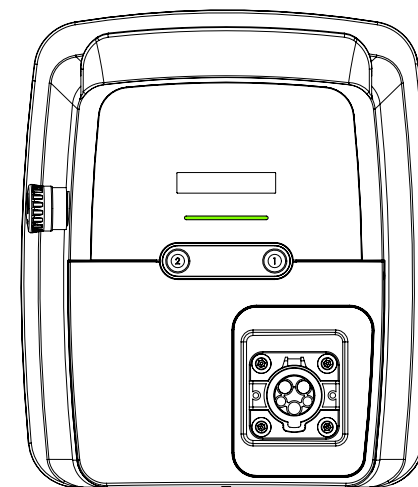

系統設定

(此功能非適用所有機種)

07

1. 系統設定說明

- 可使用手機或電腦登入充電樁設定網頁，進行相關功能設定
- 如欲由系統網頁上更改設定值，充電樁狀態須在待機中（綠燈）才能設定

(1) 請先確認設備使用模式設定為「系統設定模式」，請參照本手冊 05 充電器安裝步驟 - 使用模式設定

(2) 前往您手機或平板的 Wi-Fi 設定，連接 Evaluate 設備的 Wi-Fi：EVALUE_Charger_XXX-XX-XXXX，XXX-XX-XXXX 為 Evaluate 設備的序號後 9 碼

(3) 連上 Evaluate 設備後，輸入 WiFi 密碼：FevXXXX#，XXXX 為設備序號後 4 碼



(4) WiFi 連上後開啟瀏覽器，網址輸入 IP 位址 : 192.168.100.1，即可開啟充電樁系統網頁



使用者帳號：evalue

使用者密碼：000000

第一次登入會跳出是否需修改密碼，可進行更換密碼

2. 功能說明

(1) 使用紀錄

1. 一個頁面顯示 7 次充電紀錄
2. 點擊單次使用紀錄可顯示詳細資訊
 - 年 / 月 / 日、時 / 分 / 秒、長條圖，使用度數
 - 點下單次充電紀錄點按會顯示充電曲線 [充電時間 (x 軸) vs 電流 (y 軸)]

作業畫面



頁面顯示充電次數



使用紀錄詳細資訊

(2) 充電操作 / 充電樁狀態

1. 充電樁狀態充電中 / 待機中，狀態顯示：

- 充電樁充電中 - 顯示使用度數
- 充電樁待機中 - 顯示未開啟

作業畫面



充電樁充電中顯示



充電樁待機中顯示

2. 充電樁故障提示

作業畫面



充電樁故障提示

(3) 系統資訊

1. 系統版本

- MCU 版本：可更新下載及上傳更新
- 系統版本：可上傳更新
- MCU/ 系統：自動更新按鈕 (每次點按觸發執行自動更新一次)
- 電錶版本
- Web 版本

※ 啟用手動更新顯示提示訊息：上傳更新後顯示開始更新→更新中，請勿重整頁面→更新成功

2. 硬體版本資訊

- SN
- MAC
- ModelName
- CompanyName
- 最大電流
- Wifi RSSI 訊號

作業畫面



更新下載



更新中



系統版本資訊顯示



硬體版本資訊顯示



更新成功

(4) 自動校時

自動校時：同步開關（開啟同步時間）

作業畫面



自動校時開啟同步



自動校時關閉同步



自動校時時區設定

(5) 充電模式

充電模式選單

1. 隨插即用
2. 全卡模式
3. 卡片認證模式
4. OCPP 模式 - 充電操作區提示燈亮起

※ 需先調整充電樁指撥開關：1off, 2on, 3off (OCPP 模式) 選取設定後點擊儲存，系統重啟

作業畫面



充電模式選單



OCPP 模式提示燈亮起



儲存系統重啟提示

(6) 延遲啟動

- 於主畫面上方“設定”點擊進入系統設定
 - 輸入欲延遲充電設定之啟用充電時間
 - 輸入設定開啟時間為 24 小時制，設定時間上限為 24 小時，下限為 10 分鐘
 - 輸入完成後，欄位旁提示燈亮起
- 延遲充電設定完成後，開啟充電開關，此時延遲充電時間提示出現，且充電度數顯示為“0”，在設定時間到後才開始啟用充電，此時才會顯示充電之度數

作業畫面



延遲充電開啟提示燈亮



延遲充電關閉



充電操作區延遲充電提示



延遲充電時間下限錯誤提示

(7) 定時關閉

1. 於主畫面上方“設定”點擊進入系統設定
 - 輸入欲定時關閉設定之結束充電時間
 - 輸入完成後，欄位旁提示燈亮起
2. 真正開始充電後 (充電度數顯示不為 0), 此時定時關閉提示出現，在設定時間到後將自動關閉充電中開關
3. 輸入設定開啟時間為 24 小時制，設定時間上限為 24 小時，下限為 10 分鐘

註：隨插即用模式下，使用系統網頁操作停止充電／設定充電結束時間，須實際將充電槍取出後結束充電

作業畫面



定時關閉提示燈



充電操作區顯示



定時關閉輸入錯誤提示



關閉定時關閉輸入

(8) 網路設定

1. 無線網路
 - 無線網路改選為 DHCP，儲存後系統自動重啟
 - 將手機 WiFi 改為與儲存 WiFi 相同才可登入
2. 有線網路
 - 有線網路 增加 DHCP/Static ip 設定
 - 數入完設定點擊儲存，改使用有線網路登入

作業畫面



無線網路設定



有線網路設定

(9) OCPP 設定

- 如有後台連線需求，充電模式選擇 OCPP 模式
- 請於主機 URL 輸入位址及該後台 meter value 秒數
- 請參照以下格式
 - ws:// 後台主機 IP:port/...
 - ws:// 後台主機 URL:port/...
- 儲存後系統將會自動重新開機

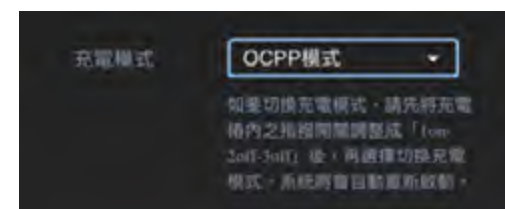

(10) Restore/ Backup Config

1. Restore Config 上傳 - 點擊上傳檔案
2. Backup Config 下載 - 點擊下載文件

作業畫面



Restore Config 上傳



Backup Config 下載

(11) WLAN IP 地址過濾

1. 點擊欄位，選擇“關閉、允許、拒絕”
2. 選取允許及拒絕時
 - 下方出現空白可輸入欄位與右邊 + 新增欄位
 - 允許：儲存後只可設定之 ip 位置登入
 - 拒絕：儲存後所設定之 ip 位置不可登入

作業畫面



WLAN IP 關閉狀態

輸入允許之 ip 位置

輸入拒絕之 ip 位置

(12) RFID 卡片管理

1. 卡片清單

- 新增卡片上限 10 張卡
- 當使用上限額滿時，出現提示訊息
- “卡片上限為 10 張，您已加入 10 張卡片”

2. 新增卡片

- 點擊“新增卡片”
- (聽到充電樁發出滴滴聲後) 將卡片靠近充電樁讀卡機，進行感應
- 讀卡成功後左上角顯示卡號
- 提示訊息“卡片感應成功，請輸入您的卡片名稱，並點擊啟動加卡”
- 輸入卡片名稱完成後點擊啟動加卡
- 加卡成功

作業畫面



新增卡片額滿提示



卡片讀取



卡片輸入名稱啟動加卡

3. 刪除卡片

- - RFID 卡片管理頁面顯示“選取所有卡片及刪除”
- - 與所設定之卡片右上角顯示可勾選欄位
- - 選取後即可刪除卡片

作業畫面



勾選選取所有卡片



刪除卡片提示

(13) 帳號密碼設定

1. 修改帳號

- - 點擊修改帳號，於輸入帳號欄位輸入新帳號
- - 輸入完畢後點擊確認修改，出現提示修改完成

2. 修改密碼

- - 點擊修改密碼
- - 先輸入舊密碼
- - 輸入新密碼後，需再次輸入新密碼確認
- - 完成後點擊確認修改，登出後使用新設定之密碼登入

作業畫面



帳號設定



修改帳號



修改密碼



修改成功

疑難排除 Q&A

08

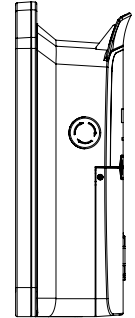
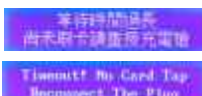
項次	LED 燈號 [註 1]	LCM 顯示 [註 2]	問題原因	排除方式
1	紅燈恆亮	「緊急按鈕啟動」 	緊急按鈕已按下啟動 	確認充電器無異常後再按一次充電器左側之緊急按鈕關閉解除
2	紅燈恆亮	「等待時間過長，尚未刷卡請重接充電槍」 	充電槍與車輛連結後超過時間（約 120 秒）未刷卡。	請將充電槍移除後重新與車輛連接及刷卡 ※

- ※ 僅適用選用 RFID 啟用卡啟用本交流充電器之用戶，如無啟動 RFID 感應功能之充電器將不會看到該錯誤畫面。
- ※ 當系統支援需重新啟動時，充電樁將每隔 2 秒閃爍黃燈三次，並持續循環，直到重啟作業完成。若在待機狀態下，充電樁無法啟動充電程序；若此時充電作業正在進行中，則不受影響，將持續正常充電。
- ※ 若設備在待機狀態下突然亮起白色燈號，表示設備正在進行清除暫存資料的操作，屬正常現象。此動作僅會在用戶充電完成後，於刷卡結束或拔槍結束後執行，充電期間不會進行此動作，以確保充電行為的完整性。該過程中設備將無法進行充電，待操作完成後方可恢復使用。
- ※ 若您觀察到燈號持續異常閃爍，並伴隨設備無法運作，請依照使用說明進行檢查，或聯絡客服支援。

項次	LED 燈號 [註 1]	LCM 顯示 [註 2]	問題原因	排除方式
3	紅燈閃爍 5 次	「輸出電流過高」	充電電流超過最大輸出電流設定值，充電器進入保護模式停止供電。	
4	紅燈閃爍 5 次	「發生故障 輸入電壓異常」 	AC IN 電壓過低或是過高，充電器進入保護模式，停止供電。	請先關閉充電器電源開關 (漏電斷路器 [註 3]) 後再重啟充電器，如仍持續發生請聯繫專業人員協助。
5	紅燈閃爍 9 次	「發生故障電錶異常」 	充電器內建電表發生錯誤。	
6	紅燈閃爍 3 次	「卡片錯誤」 	使用之感應卡片損壞或使用非經設定過之感應卡片該充電器之感應卡片。	
7	紅燈閃爍 五次	「溫度異常 OTP」	充電器內部偵測溫度異常。	請在雙手乾燥情況下將電力箱內的漏電保護器重新開關，此步驟為先行排除是否為供電端的問題，如仍持續發生請聯繫專業人員協助。

* 僅適用選用 RFID 啟用卡啟用本交流充電器之用戶，如無啟動 RFID 感應功能之充電器將不會看到該錯誤畫面。

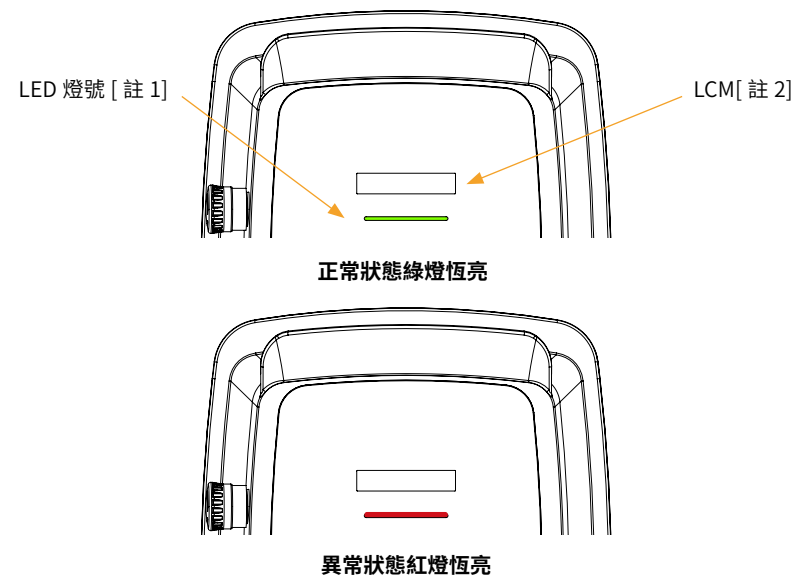

例如：當「尚未感應卡片請拔除充電槍」異常發生時，紅燈恆亮至異常問題排除。



註：本設備應依現場條件選用適當的無熔絲開關 (MCCB)，並必須搭配安裝漏電斷路器，以確保用電安全。

充電器有限品質保養

09

1. 一般條款

- 本充電器自保固起算日保固 2 年，保固範圍包含充電器本體及其內部電子元件（耗材除外，如：保險絲）、充電槍，保固貼紙如有破損、拆除痕跡或人為破壞時，如仍於保固期限內亦不予以保固。
- 華城電能有限品質保養承諾從華城電能充電器產品安裝日起，二年（“質保期”）內享受由於充電器本身出現的故障質保。包括但不限於因下述情形導致華城電能充電器出現缺陷或受到損壞，不享受有限保修待遇：
 - 因正常磨損或老化、誤用、濫用、疏忽、事故、不當使用、存放環境導致的任何直接或間接損壞或故障。
 - 無遵守華城電能充電器依本《操作手冊》的操作說明及注意事項。
 - 外部因素，包括但不限於用物件撞擊華城電能充電器、周圍存放環境或天災（包括但不限於火災、地震、洪水、閃電以及其他環境情況）。
 - 一般的外觀損壞，包括刮痕、凹陷或龜裂。
 - 未獲華城授權或許可標章的個人或機構以任何方式維修、更換或改裝華城電能充電器，或安裝或使用任何零件或配件。
 - 缺乏或不當的維修或保養；以及包括使用非華城電能所提供的配件或零件。
 - 因使用任何轉接器或轉換轉接器，或是非對車充電行為導致設備無法正常作動，皆無法保固。

2. 責任限制

- 如非經華城電能認證之專業人員施工安裝充電器而造成設備損壞，則不在保固範圍內，若有發生任何人員或財產傷害，本公司皆不負任何法律責任與損害賠償。
- 針對上述針對上述權利未涵蓋的部分，華城電能不承擔本《操作手冊》所載之補救措施以外的責任，包括但不限於任何產品無法使用、利益損失、業務損失，或是資料或軟體遺失、損毀、受損，或服務條款之責任。除明確指出者外，華城電能不承擔任何衍生性、特別的、間接的、懲罰性損害之責任（即使華城電能已知悉可能發生這類損害），或負責任何第三方提出的求償。針對任何與購買產品相關的責任，您同意 華城電能 均不承擔或負起支付超出您訂購金額的任何賠償金額之責任。在消費者的投訴中，協助釐清重大傷亡或是刑事犯罪事件的責任範圍可能比疏忽導致的損害還廣，在此情況下，華城電能不會試圖排除相關責任。

3. 保養

- 充電器表面如有灰塵或髒汙可用擰乾的抹布進行表面擦拭，不可使用有機溶劑或揮發性液體擦拭避免損壞充電器外殼及引起火災的風險。
- 可由所在地合格之電機專業人員定期檢測外部開關箱內無熔絲開關的一二次側接點是否有

鬆脫或異物。

- 長時間不使用充電器時，可將外部開關箱內的無熔絲開關關閉。

主型號：

CBDA-X80A

系列型號：

CBDA-X80-A4、CBDA-X80-A7、CBDA-X70A、CBDA-X50A、CBDA-350A、
 CBDAX50A-A4、CBDA-X50A-A6、CBDA-X50A-A7、CBDA-X40A、CBDA-X40A-A6、
 CBDAX32A、CBDA-X32A-A6、CBDA-X24A、CBDA-X24A-A6、CBDA-X16A、CBDA-
 X16A-A6、CBDA-X70B、CBDA-X70B-A4、CBDA-X70B-A7、CBDA-X50B、CBDA-X40B、
 CBDAX32B、CBDA-X32B-A4、CBDA-X32B-A7、CBDA-X32B-Y1、CBDA-X24B、CBDA-
 X16B

機種型號	額定電流_A	輸出功率_kW	充電槍規格	重量_kg
CBDA-X80A、CBDA-X80A-A4、CBDA-X80A-A7	80	17.6	SAE J1772	10.5
CBDA-X70A	70	15.4	SAE J1772	10.5
CBDA-X50A、CBDA-X50A-A4、CBDA-X50A-A6、CBDA-X50A-A7、CBDA-350A	50	11	SAE J1772	9.2
CBDA-X40A、CBDA-X40A-A6	40	8.8	SAE J1772	9.2
CBDA-X32A、CBDA-X32A-A6	32	7.04	SAE J1772	9.2
CBDA-X24A、CBDA-X24A-A6	24	5.28	SAE J1772	9.2
CBDA-X16A、CBDA-X16A-A6	16	3.52	SAE J1772	9.2
CBDA-X70B、CBDA-X70B-A4、CBDA-X70B-A7	70	15.4	IEC 62196	10.4
CBDA-X50B	50	11	IEC 62196	10.4
CBDA-X40B	40	8.8	IEC 62196	10.4
CBDA-X32B、CBDA-X32B-A4、CBDA-X32B-A7、CBDA-X32B-Y1	32	7.04	IEC 62196	7.9
CBDA-X24B	24	5.28	IEC 62196	7.9
CBDA-X16B	16	3.52	IEC 62196	7.9

華城電能科技股份有限公司

115602 臺北市南港區三重路 66 號 12 樓

TEL：(02)2325-3320 FAX：(02)2325-3350

官方網站：www.evaluate.com.tw

客服信箱：service@f-evaluate.com

Made in Taiwan

Contents

1.About This Operating Instruction Manual.....	64
Error or Omission	65
Copyright & Trademark.....	65
2.Safety information.....	66
Important Safety Instruction.....	67
Warning	67
Precautions	68
3.Specification.....	70
Product Physical Appearance.....	71
Product Specification.....	72
Function.....	73
4.Preparation for Installation.....	76
Minimum Requirements	77
Power Supply Cable.....	78
Power Supply Mode	78
Selection of Residual Current Circuit Breakers (RCCBs).....	78
Confirm if Rated Capacity of Your No Fuse Breaker Able to Meet Requirements.....	77
Selection of Best Position for Wall mounted EV charger.....	77
Precautions for Installation.....	78
Check Contents.....	79
5.Installation Steps of Charger.....	80
Tools & Material.....	81
Installation Steps of Wall mounted EV charger.....	82
Wiring Preparation of Cables	85
Wiring of Cables.....	86
Setting the operation modes	87
Confirmation of Current Needs & Test.....	88
Power-on Test & Assembly.....	89
wiring diagram.....	90
6.Operating Instruction.....	92
Standby Page.....	93
Prior to Charge	94
Start to Charge.	95
End of Charge.....	96
Completion of Charge.....	97
7.System setting.....	98
8.Troubleshooting Q&A	120
9.Limited Quality Maintenance of Charging Equipment.....	124
General Terms.....	125
Limitation of Liability.....	125
Maintenance.....	126

About This Operating Instruction Manual

01

Error or Omission

If you would like to convey any recommendation or omission with respect to this "Operating Instruction Manual", you are welcome to send your comments or recommendation to this email address: service@f-evalue.com

Copyright & Trademark

All the information contained in this "Operating Instruction Manual" is protected by the copyright of Fortune Electric Value Co., Ltd. and the other laws of intellectual property right. Without the prior written permission of Fortune Electric Value Co., Ltd., all or part of the contents contained in this "Operating Instruction Manual" shall not be revised, reproduced or copied.

The product specifications are subject to change without prior notice.

Safety information

02

Important Safety Instruction

This operating instruction manual includes the important instruction and warning which shall be followed during the installation and maintenance of wall mounted EV charger.

Warning

- Prior to use this product, please read all instructions.
- If there is any child nearby while using this product, monitor and control the child shall be required and pay attention to safety.
- The charger shall be grounded through the permanent wiring system or the protective grounding conductor.
- Please do not install or use the charger around the combustible, explosive, irritating or flammable materials, chemical goods or gases.
- Prior to install or clean the charger, please turn off the input power on the circuit breaker.
- Please strictly follow the specified operating parameters for using the charger.
- Please do not spray water or any other liquid directly on the switch box installed on the wall. Please do not spray any liquid on the charging gun or immerse the charging gun in the liquid. Please place the charging gun on the base to prevent from contacting with the unnecessary contaminant or moisture.
- If the charger has defect, appears crack, wear, fracture or damage so that it cannot be used or operated, please stop using or do not use it.
- Please do not attempt to disassemble, repair, improperly adjust or modify the charger. The user shall not repair the charger by himself. If any repair or modification is required, please contact with the Fortune Electric Value Co., Ltd.
- Please be careful during the shipment of charger. Please do not subject the charger to strong force or impact, or pull, twist, tangle, drag or step on the charger to prevent from damage to the body or any component.
- Please do not contact with the end of charging gun head with your fingers or sharp metal object (such as electric wire, tool or needle etc.).
- Please do not fold any part of the charger or put pressure on it, or damage it with sharp object.
- Please do not insert foreign object into any part of the charger.
- The use of charger may affect or damage the operation of medical or implantable electronic equipment, such as the implantable pacemaker or implantable defibrillator. Prior to use the charger, please consult with the manufacturer of electronic equipment with respect to the impact of charging on such electronic equipment.

Precautions

- Please do not use the generator as the power supply source for charging operation.
- The incorrect installation and test of charger will cause the potential damage to the vehicle battery and/or the charger itself. Any damage caused by these will not be covered

by the warranty.

- Please do not operate the charger under the temperature outside the operating range i.e. -13 °F to 122°F (-25°C to 50°C).
- If using a network cable, the length must not exceed thirty meters.
- This charging device must be used with a certified non-fuse switch overload protector and leakage protection circuit breaker to comply with the national BSMI VPC (Voluntary Product Certification) certification requirements. If you have any questions about installation, please contact EVALUE for consultation or purchase qualified materials. If the non-fuse switch overload protector and leakage protection circuit breaker are not used, the user shall be responsible for the abnormality or other problems of the charging equipment.
- Do not use adapters or conversion connectors.
- Do not use extension cord sets.

1.Product Physical Appearance

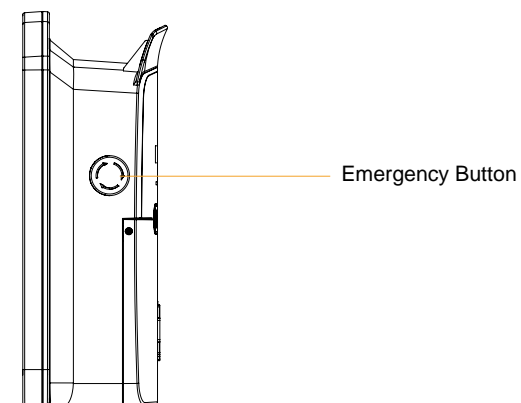
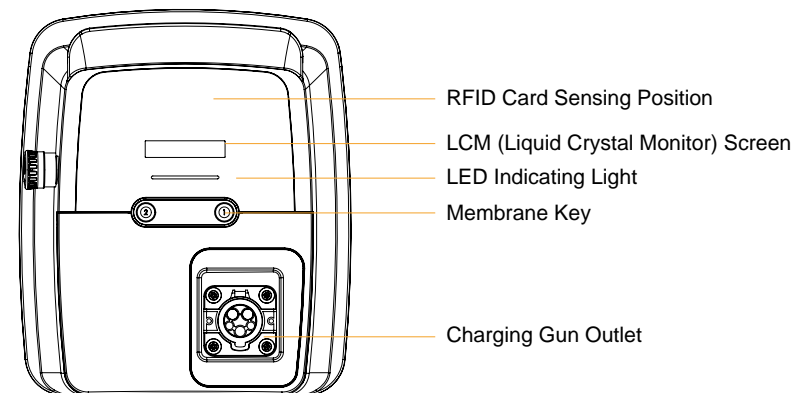

Specification

03

2. Product Specification

Description	Specification
Voltage Specification	<ul style="list-style-type: none"> Voltage Used: 220V Single-phase AC: L, Neutral & Ground Cable Voltage Range: 220V AC between N end and L end
Frequency Range	60 Hz
Output Current	CBDA-X32B: (Highest)32A CBDA-X50A: (Highest)50A CBDA-X70B: (Highest)70A CBDA-X80A: (Highest)80A
Power Output	CBDA-X32B: (Highest)7.04KW CBDA-X50A: (Highest)11KW CBDA-X70B: (Highest)15.4KW CBDA-X80A: (Highest)17.6KW
Charging Gun Specification	CBDA-X32B \ CBDA-X70B: IEC 62196 CBDA-X50A \ CBDA-X80A: SAE J1772
Cable Length	5m
Physical Dimension of Charger	Length: 393.8mm / Width: 338.54mm / Height: 144.53mm
Weight (including charging gun cable)	CBDA-X32B: 7.9kg CBDA-X50A: 9.2kg CBDA-X70B: 10.4kg CBDA-X80A: 10.5kg
Buttons	Emergency Stop Switch, Button 1, Button 2
Indicating Lights	Standby: Green Light, Under Charging: Blue Light, Full Charge: Flashing Green Light, Error: Red Light
Identification of User Identity	RFID Card Reader (Note: Enable or disable identify identification function is selectable)
LCM Liquid Crystal Display	Both Chinese & English Display
Protection Function	Overvoltage Protection, Low voltage protection, Over Current Protection, Short Circuit Protection, Overload Protection, Over-temperature protection
Operating Temperature	-25°C to 50°C
Humidity	<95% Relative Humidity
IP Dustproof/Waterproof Class	IP55
Certification Standard	CNS15511

(Note: Please check page 126 for complete series specifications.)

3. Function

(1) Selectable Rated Current

a. Type : CBDA-X32B

The output of rated current can be adjusted in accordance with the field needs. The current ranges of this adjustable charger are 6, 16, 24 or 32A.

b. Type : CBDA-X50A

The output of rated current can be adjusted in accordance with the field needs. The current ranges of this adjustable charger are 6, 16, 24, 32 or 50A.

c. Type : CBDA-X70B

The output of rated current can be adjusted in accordance with the field needs. The current ranges of this adjustable charger are 6, 16, 24, 32, 50 or 70A.

d. Type : CBDA-X80A

The output of rated current can be adjusted in accordance with the field needs. The current ranges of this adjustable charger are 6, 16, 24, 32, 50, 70 or 80A.

(Note: It shall be adjusted at the time of installation. If further adjustment is still required after the installation is completed, the qualified professional electrician shall be called for assessment and setting.)

(Note: Please check page 126 for complete series specifications.)

(2) Start of Delaying Charge

If it is intended to delay the starting time of charge, press the button 2 to preset the starting time of charge after 1, 2, 4 or 8 hours.

Example: The current time is 10:00, and it is intended to start the charge after 2 hours, so press the button 2 twice, and the charger will automatically start the charging function upon the end of 2 hours countdown.

(Note: The charging connector to the vehicle shall be properly connected)

(3) Add/Delete Cards

Add Card (only one card number can be added at a time):

a. Press the emergency button, the LED light turns red.

b. Press and hold the function key ①, release it after hearing two beeps. The blue/green lights will blink alternately, indicating that it has entered the card addition mode (ignore the text on the screen).

c. Bring the card close to the RFID card reading area. After hearing a long beep, the system will return to the red light status, indicating that the card number has been added.

d. Restore the emergency button, and the LED light will turn green, indicating that the charging station is in standby mode.

Delete Card (delete all card numbers):

a. Press the emergency button, the LED light turns red.

b. Press and hold the function key ① , release it after hearing two beeps. The blue/green lights will blink alternately, indicating that it has entered the card addition mode (ignore the text on the screen).

c. Press the function key ② briefly. The blue/red lights will blink alternately, indicating that it has entered the card deletion mode (ignore the text on the screen).

d. After entering the deletion mode, press and hold function key ① until you hear a long beep, then release it. The system will return to the red light status, indicating that all card numbers have been deleted. e. Restore the emergency button, and the LED light will turn green, indicating that the charging station is in standby mode.

(4) Restore Factory Settings(Excluding OCPP mode)

a. Press the emergency button, the LED light turns red.

b. Press and hold the function key ① , release it after hearing two beeps. The blue/green lights will blink alternately, indicating that it has entered the card addition mode (ignore the text on the screen).

c. Press the function key ② briefly. The blue/red lights will blink alternately, indicating that it has entered the card deletion mode (ignore the text on the screen).

d. Press the function key ② briefly again. The green/red lights will blink alternately, indicating that it has entered the restore factory settings mode (ignore the text on the screen).

e. Press and hold the function key ① , the LED light will flash white. Press and hold the function key ① again to confirm the restore factory settings. The LED light will flash purple, indicating that the factory settings have been restored.

f. Restore the emergency button, and the charging station will be ready to reboot. The screen

will display "Device is booting...". The LED light will turn from red to white. Please wait for the system to start up (about 3 minutes).

g. The LED light will turn green, indicating that the charging station is in standby mode.

Preparation for Installation

04

1. Minimum Requirements

- Measure the load of power supply and confirm it is able to meet the maximum current of charger.
- The rated current size of spared or newly added no-fuse breaker in the switch box shall be 1.25 times greater than the maximum current of charger.
- Confirm the field voltage and wiring distance, and calculate if the voltage drop is able to meet the local regulations or the minimum requirements of charger.

2. Power Supply Cable

- The cable shall use the insulation-jacketed copper wire certified by the local country, and the withstand current of wire shall be 1.25 times greater than the rated current of no fuse breaker.
- When selecting connection cables, it is essential to consider potential derating factors and elevated ambient temperatures within the internal charging connection area. Under certain conditions, this may necessitate increasing the cable cross-sectional area and selecting cables with enhanced temperature resistance to ensure safe and reliable operation.

3. Power Supply Mode

The power used by charger is the single-phase 3-wire 220V, which is compatible with 3-phase 4-wire 220V/380V, single-phase 3-wire 110V/220V, single-phase 2-wire 220V and 3-phase 3-wire 220V. (Note: It is recommended that the power distribution/wiring shall be performed by the qualified power technician or engineer to avoid the electric shock or short circuit accident occurred on the personnel.)

4. Confirm if Rated Capacity of Your No Fuse Breaker Able to Meet Re-quirements

- Confirm the specification of your main switch. Please check the distribution panel or switch box to determine the current amount available for the power source at the installation site.
- When selecting overcurrent protection switches, it is important to assess the impact of elevated ambient temperatures within the switch cabinet. In specific situations, it may be necessary to reduce the charging current setting to ensure system stability and availability. The rated current should be determined based on actual charging requirements, available connection power, and equipment nameplate information.
- The overcurrent protection device must comply with relevant standards such as CNS 14816-2, IEC 60947-6-2, IEC 61009-1, or the CNS 14985 series and IEC 60269 series.
- The charger has the built-in rotary switch for you to adjust its working current. The selection of rated current for the spared or newly added no fuse breaker shall be performed in accordance with the continuous current value of following values i.e. 6, 16,

24,32,50,70 or 80A to select the appropriate no fuse breaker.
(Note: Please check page 126 for complete series specifications.)

5. Selection of Residual Current Circuit Breakers (RCCBs)

Connection cables must be installed within building facilities that comply with national legal regulations and relevant statutory requirements.

Please note:

- Each charging station must be connected through an independent residual current circuit breaker (RCCB), which must not be shared with other circuits.
- In Taiwan, a Type B RCCB or an EV-specific Type A RCCB must be installed. The rated current of the RCCB must exceed the rated current of the charging station. The RCCB used must comply with one of the following standards: IEC 61008-1, IEC 61009-1, CNS 14816-2, or IEC 62423.

6. Selection of Best Position for Wall mounted EV charger

Confirm the parking position to ensure that the charging cable is able to connect to the charging connector at the vehicle end. The charger shall be placed at the following positions:

- In the enclosed garage, it is usually located next to the charging connector of vehicle.
- A well-ventilated place, avoid install in the enclosed case body or near the heat transfer device.
- The indoor charger shall be installed at the position of 45 cm or more above the ground but less than 120 cm.
- The outdoor charger shall be installed at the position of 60 cm or more above the ground but less than 120 cm.
- The charger body shall be 20 cm or more away from the surrounding obstacles, so that the cable is able to wrap around the charger body during the storage.

7. Precautions for Installation

- Prior to the installation, please confirm that the switch of power supply is turned off and the power is cut off and the preventive measures are taken to avoid the electric shock hazard occurred to the personnel during the installation process of charger.
- The wiring process shall performed in accordance with the related local power regulations for proceeding the installation.
- The charging station itself does not have a power switch. A fault current circuit breaker or a household-installed circuit breaker can be used as a power isolation switch.

8. Check Contents

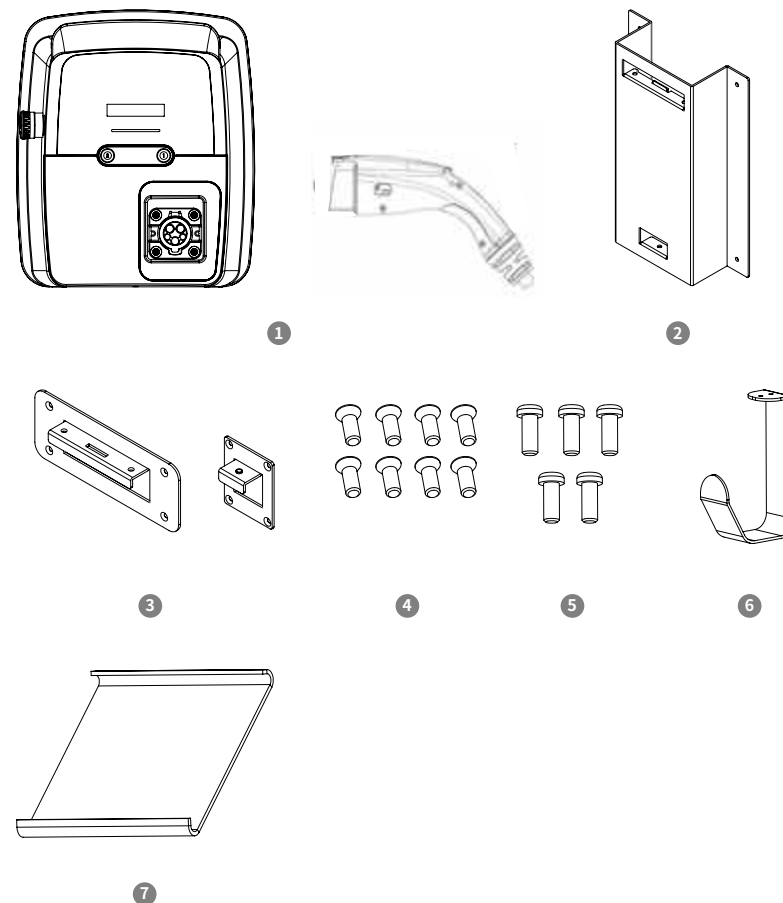

Item	Description	Qty
1	Wallbox Body & Charger Cable	1
2	Metal Parts of Wall Hanging	1
3	Countersunk Screw for Wall Hanging (M3 X 8L)	2
4	Wall Hanging Mount	8
5	Wall Hanging Mount & Cable Hook Round Head (M4 X 12L)	5
6	Cable Hook	1
7	Cover Plate of Terminal Block	1

Installation Steps of Charger

05

1. Tools & Material

- Pencil or sign pen
- Electrician's plier
- Wire stripper
- 2mm² ~ 14mm² crimping plier
- Measuring tape
- Multimeter or digital multimeter
- Phillips screwdriver
- Small flat head screwdriver
- Spirit level
- Electric drill and bits
- Plastic anchor
- Round terminal R8-6
- Torque screwdriver

2.Installation Steps of Wall-type Charger

- (1) Use the mount as the guide to mark the drilling position on the mounting wall.
- a. Use 5.8mm cement bit to drill the hole and embed the 2' plastic anchor in the hole.
 - b. Use the screws to lock and fix the wall hanging mount on the wall surface (please pay attention to the direction of wall hanging mount).

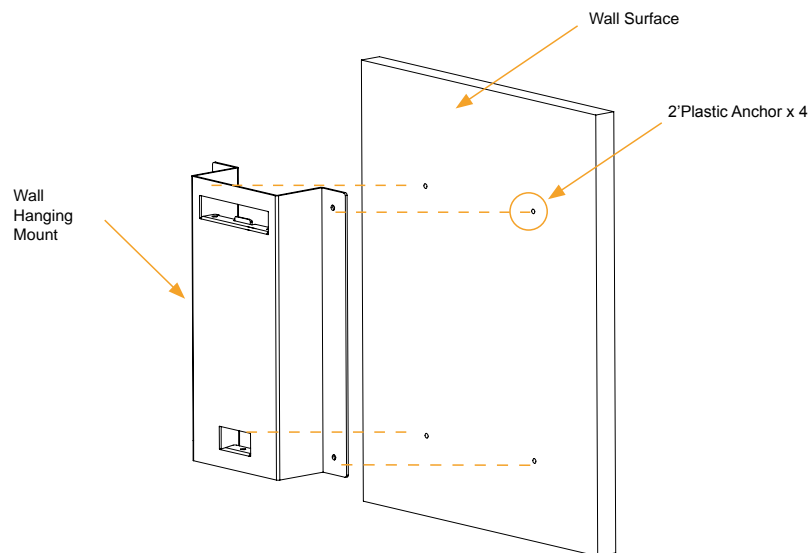

- (2) Assembly of Hook of Wall Hanging Mount & Hook of Cable
- a. Use M3 countersunk screws in the attached screw pack to fix the upper and lower hooks of wall hanging mount to the back plate of charger.
 - b. Use the M4 round head screws in the attached screw pack to fix the hook of charging gun cable to the bottom left of charger.

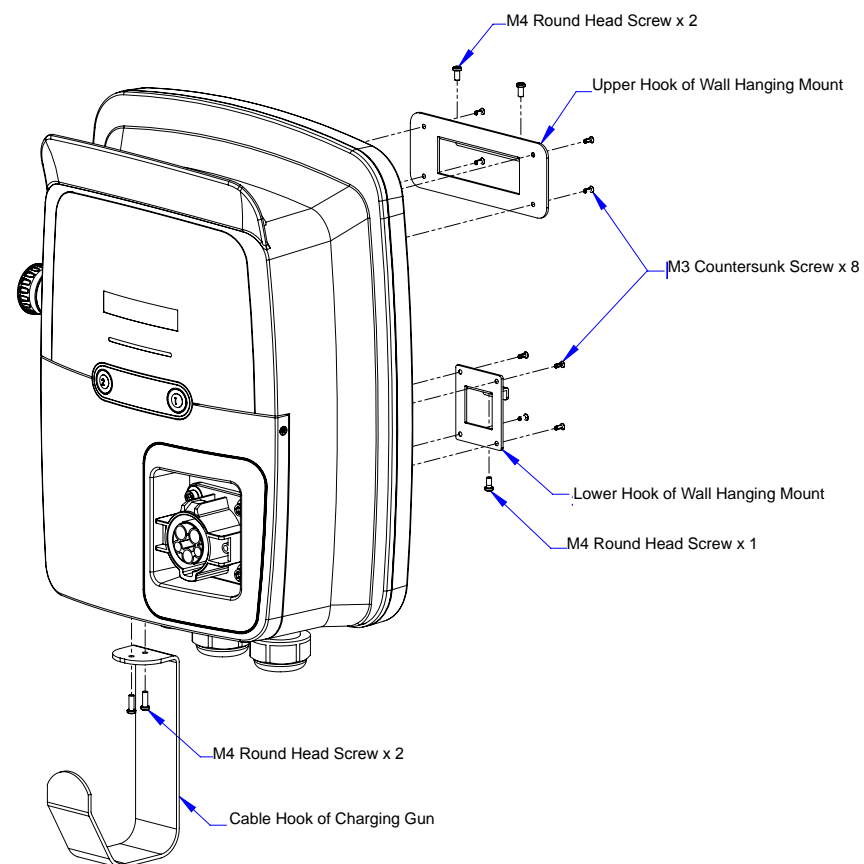

(3) Hang the charger body to the mount fixed on the wall, and use M4 round head screws in the attached pack to fix the upper hook and mount.

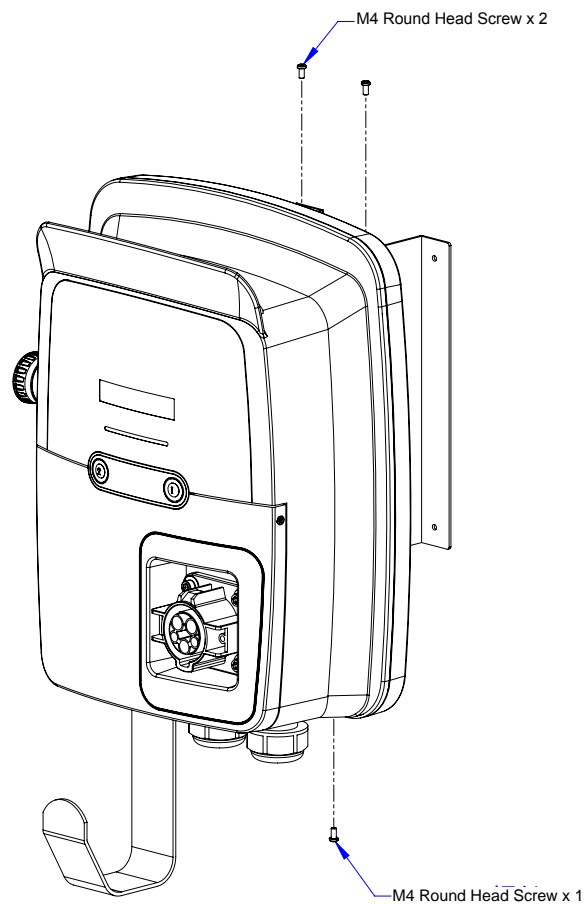

3.Wiring Preparation of Cables

- (1) Use a Phillips screwdriver to remove the outer cover housing and inner seal plate of charger.
 - a. Carefully remove the crosshead countersunk screws on the left/right and bottom of outer cover housing, and remove the outer cover.
 - b. Carefully remove the Phillips round head screws on the 4 corners in front of the inner seal plate, and remove the seal plate.

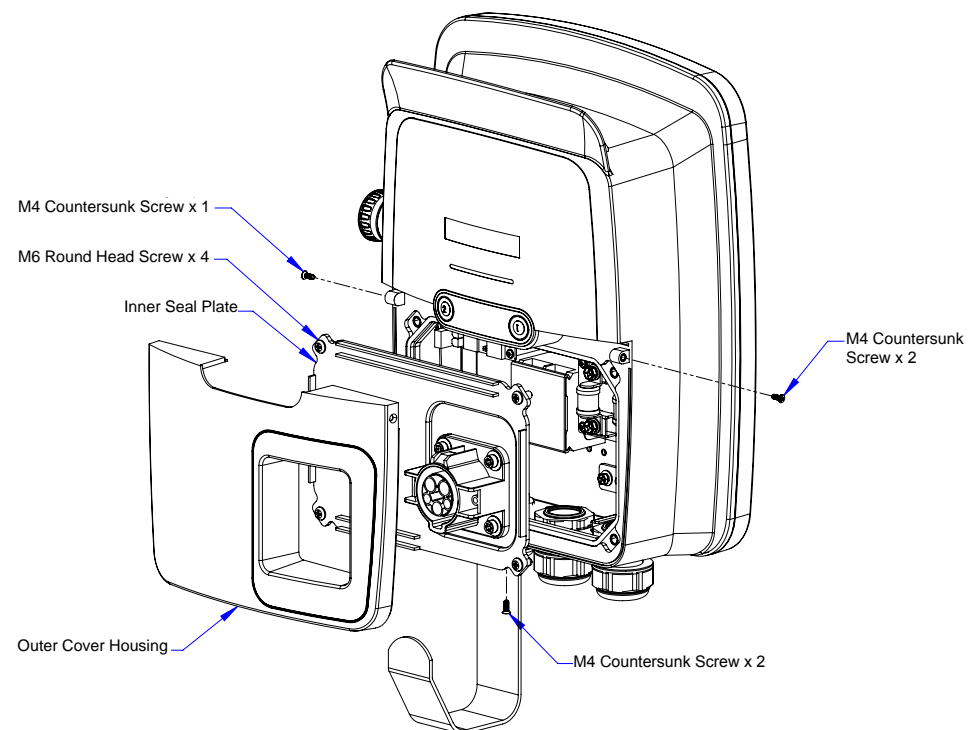

4. Wiring of Cables

(1) Remove the transparent protective cover on the terminal block, and insert the cable through the cable fixing head under the charger body, and fix the cable on the terminal block.

- a. Unscrew the cable fixing head of cable inlet by turning counterclockwise, and tight the cable fixing head by turning clockwise after inserting into the cable about 10 ~ 15cm, and pull slightly to confirm that the cable will not be moved.
- b. After crimping L1, L2 of the cable and the ground wire with the round terminals respectively, use the torque screwdriver to tight Lin, Nin and GND attached on the terminal block (4 N-m), and assemble back the transparent protective cover of terminal block . (Note: The color of L1, L2 and ground wire shall be marked in accordance with the national or local regulations.)

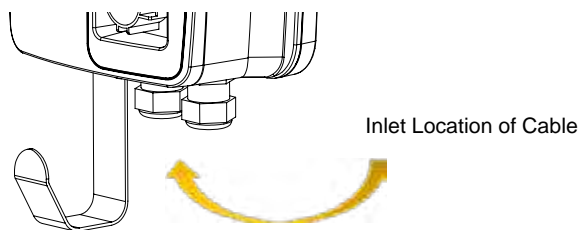

LiveWire Live wire or Neutral Wire Ground Wire

Terminal Block in Charge Body

5. Setting the operation modes

The wall-mount charger can be adjusted the operating mode according to your needs. Settings of the corresponding modes as below:

Attention: Please ensure if extra RFID cards are needed and confirm user's setting preferences at the preliminary evaluation

	Plug-and-play Function (default)
	RFID Card Reading
	OCPP Mode (Remark: This function only supports OCPP backend hosing server)
	Full Function
	System Setting Mode (Noted: If there is a need for EMS or custom backend integration, please use this setting)

5. Confirmation of Current Needs & Test

(1) The default charging current for charger is 32A, confirm if the output current is required to adjust, if the output current is required for adjustment, please refer to the table below.

(2) Turn on the no fuse breaker of power source and use the multimeter or digital multimeter to confirm if the input voltage is 220V ± 10%., open the leakage circuit breaker after confirming the voltage is correct.



Adjustment Switch for Output Current

	Output Current
0	By the charger cable serial number.
1	6
2	16
3	24
4	32
5	50
6	70
7	80
8	40

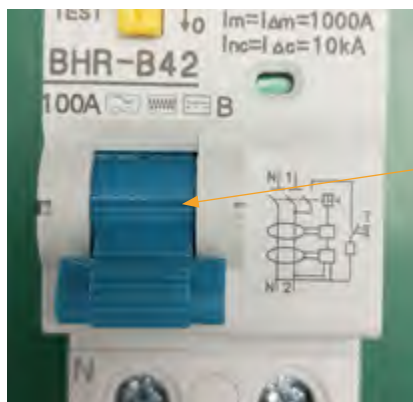

Leakage Circuit Breaker

Upward to Open ON

6. Power-on Test & Assembly

(1) The LCM and LED lamp of charger are lit after power on and perform the self-test.

- a. The charger starts the initialization and detects the maximum output current value, the standby page of "Charger Standby" is displayed after confirming the current value is correct.
- b. Tight back the inner seal plate and outer cover housing in sequence. (Note: If the seal plate and outer cover housing are completely fitted to the body.)



7.wiring diagram

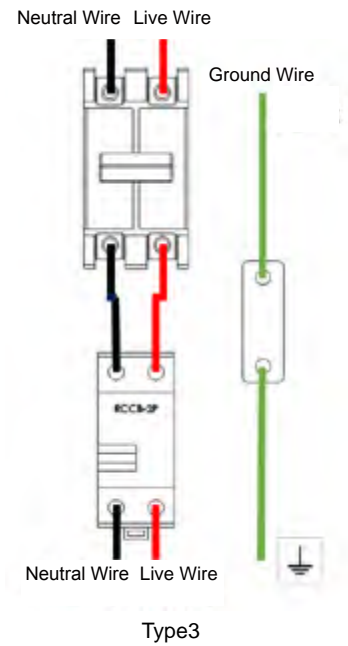
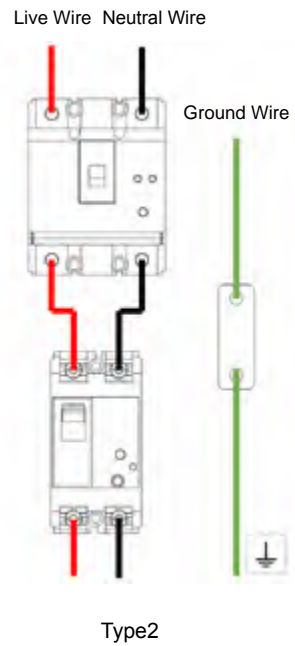
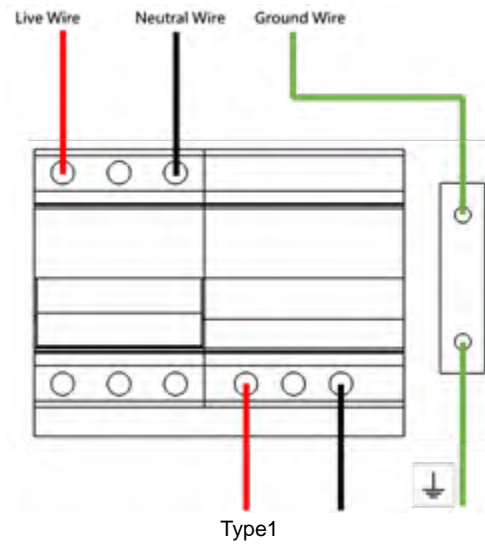

Operating Instruction

06

1. Standby Page

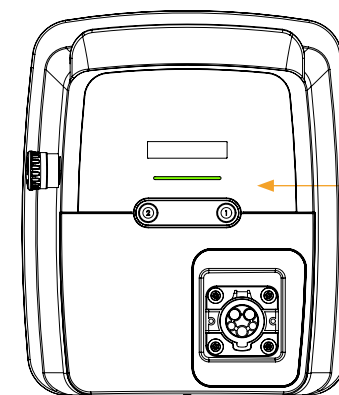

Charger Standby
充電器待機中

Precautions:

- (1) This equipment is only used by the electric vehicle.
- (2) Please do not remove the charging gun forcibly during the charging process.
- (3) If the rain drops on the connector of charging gun due to the heavy rain, please wipe off the raindrop prior to use.
- (4) If the emergency situation occurs during the charging process, please press the red emergency button on the left to stop the charge immediately, such as: electric shock of personnel, abnormal at vehicle end, etc.
- (5) If you have any question during the using process, please call customer service number 02-23253320 at the Fortune Electric Value Co., Ltd.

2. Prior to Charge

- The original setting is 0 hour prior to charge. When the Button 2 is pressed, it is able to preset that the charge starts after 1, 2, 4 or 8 hours. After pressing up to 8 hours, it will return to the original setting after pressing it once again.
- The DELAY setting can only be set while the standby mode (green light). If the cancel is required, Button 2 shall be pressed for returning to the original setting.

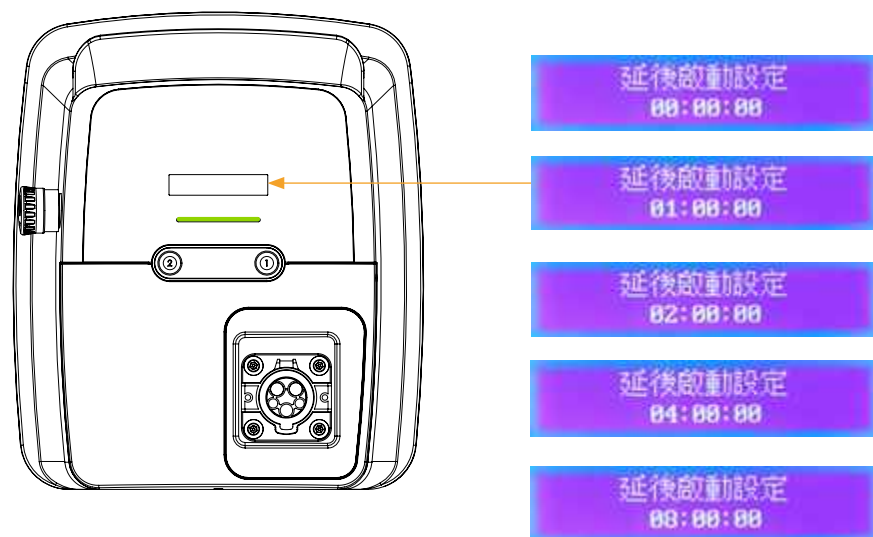

3. Start to Charge

- Remove the charging gun and connect to the charging connector of electric vehicle.
- When perform the charge, the indicating light switches from the steady green light to the steady blue light.
- The LCM displays the currently voltage, current and degree in Chinese/English alternately during the power supply process.

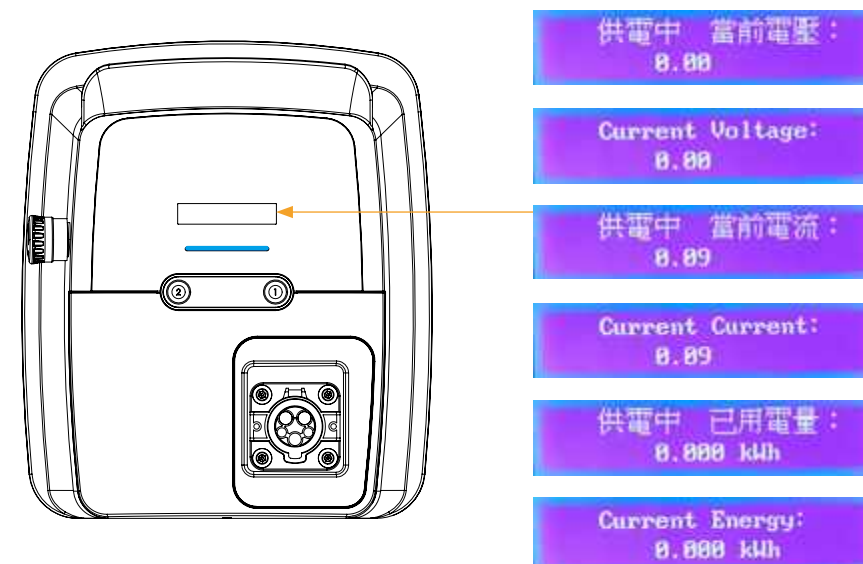

4. End of Charge

- After completing the charge, the indicating light switches from the steady blue light to the flashing green light.
- The LCM displays the current degree and time in Chinese/English alternately.

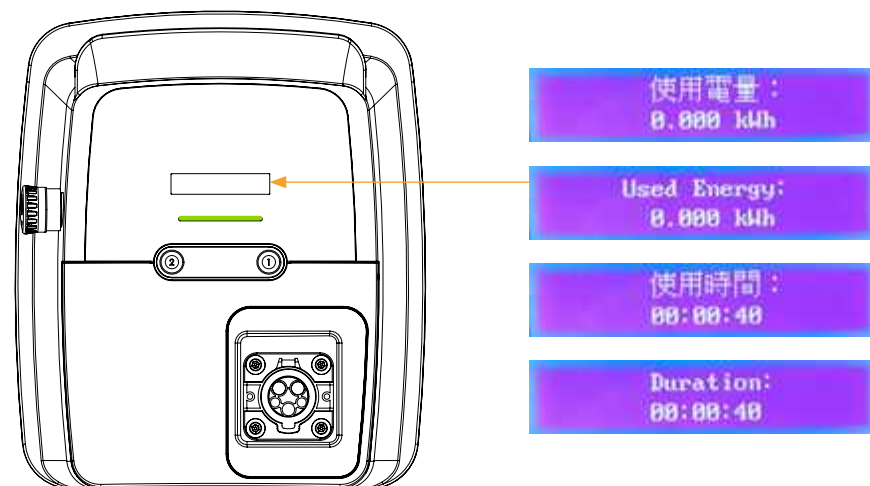

5. Completion of Charge

Take out the charging gun and place back to the charging outlet, the indicating light switches from the flashing green light to the steady green light.

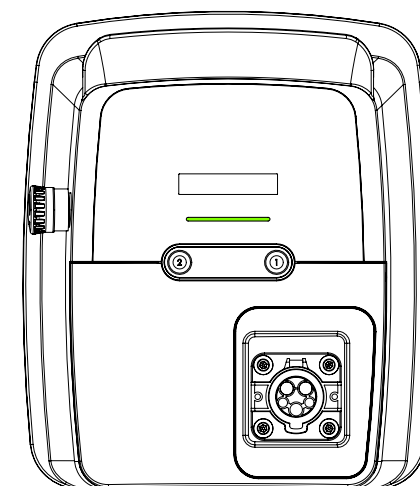

System setting

(The function is not available for all models.)

07

1. System Setup Instructions

- You can use your mobile phone or computer to log in to the charging pile setting webpage and set related functions.
- If you want to change the setting value from the system web page, the charging pile status must be in standby (green light) before setting

(1) Please first ensure the device is set to "System Setup Mode" in the usage mode settings. Refer to this manual, Section 05: Installation Steps of Charger - Setting the operation modes

(2) Go to the Wi-Fi settings on your phone or tablet, connect to the Evalue device's WiFi: EVALUE_Charger_XXX-XX-XXXX.

Note: XXX-XX-XXXX represents the serial number of the Evalue device.

(3) After connecting to the Evalue device, enter the WiFi password: FevXXXX#, where XXXX is the last 4 digits of the device serial number.



(4) When connected After connecting to WiFi, open a web browser and enter the charging station's ethernet IP address to access the charging station system webpage.

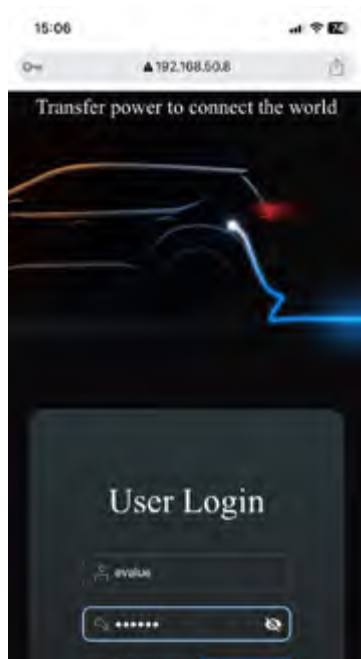

User Account : evalue
 User Password : 000000
 The first time you log in, you will be prompted to change your password. You can proceed to change your password at that time.

2. Function Description

(1) Usage Record

1. One page displays 7 charging records.

2. Clicking on a single usage record will show detailed information

- Date (year/month/day), time (hour/minute/second), bar chart displaying usage, and electricity consumption.
- Clicking on a single charging record will display the charging curve [charging time (x-axis) vs. current (y-axis)].

User Interface



Charging records



Detailed Charging Record Information

(2) Charging Operation/ Charging Station Status

1.Charger Status - On/Off, Displayed as:

- Charging On - Displays Usage
- Standby mode - Displays Not Enabled

User Interface

2.Fault Indicator

User Interface

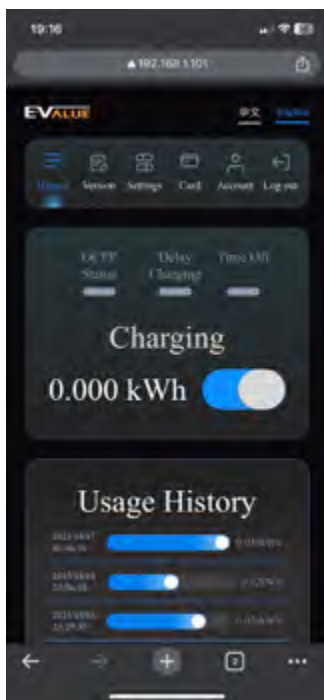

Charger Charging mode Display



Charger Standby mode Display

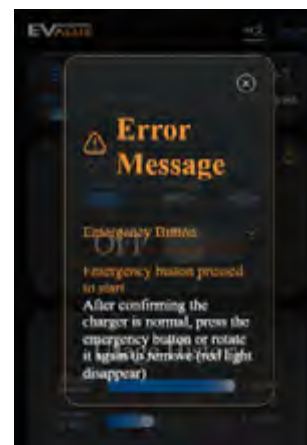

Charging Pile Error Message

(3) Information

1. System information

- MCU version Update Download and Upload Available
- System version Update Available for Upload
- MCU/system Automatic Update
- Meter version
- Web version

Enable manual update to display the following messages:

After uploading the update, the message will show: "Update Started", "Updating, please do not refresh the page", "Update Successful"

2. Hardware Version Information

- SN
- MAC
- ModelName
- CompanyName
- Maximum Current
- Wi-Fi RSSI Signal

User Interface



System Version Display



Hardware System Version Display



Update Download

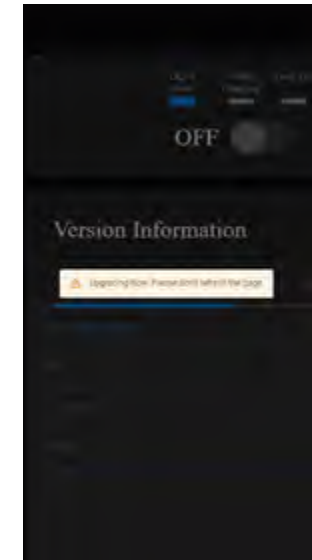

Upgrading



Update successfully

(4) Automatic Time Calibration

Automatic Time Calibration : Synchronization Switch (Enable Time Synchronization)

User Interface

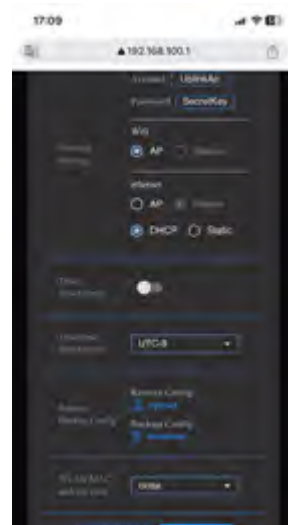

Automatic Time Calibration Turned On for Synchronization

Automatic Time Calibration Turned Off for Synchronization



Automatic Time Calibration Time Zone Setting

(5) Charging Mode Menu

1. Plug-and-play Function
 2. Full Function
 3. RFID Card Reading
 4. OCPP Mode - Charging Control Area Indicator Light Illuminated
- The charging pile DIP switches need to be set first: 1 off, 2 on, 3 off (OCPP mode).
After selecting the settings, click save, and the system will reboot.

User Interface



Charging Mode Menu

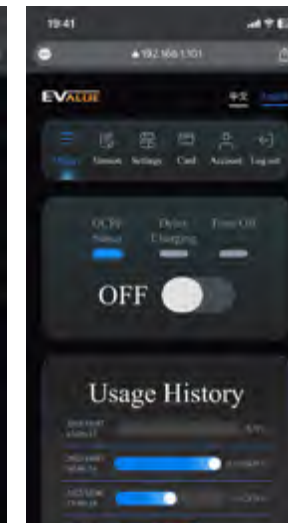

OCPP Mode Indicator Light Illuminated

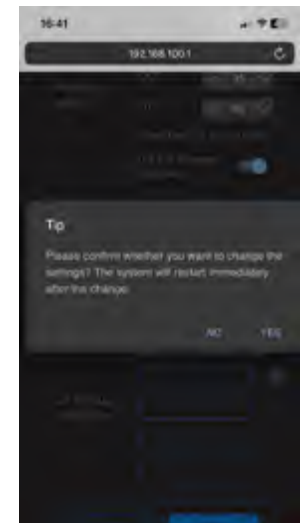

System Reboot Indicator

(6) Delaying Charge

1. On the main screen, click on "Settings" at the top to enter the system settings.

- Enter the desired charging delay setting in the "Enable Charging Time" field.
- Enter the setting in a 24-hour format, with a minimum delay of 10 minutes and a maximum of 24 hours.
- Once you've entered the setting, the indicator light next to the field will illuminate.

2. After completing the delayed charging setting, turn on the charging switch. At this point, the delayed charging time indication will appear, and the charging usage will display as "0." Charging will only begin after the set time has elapsed, and at that time, the charging usage will start to display.

User Interface



Delayed Charging Enabled Indicator Light Illuminated



Delayed Charging Off



Charging Control Area Delayed Charging Notification

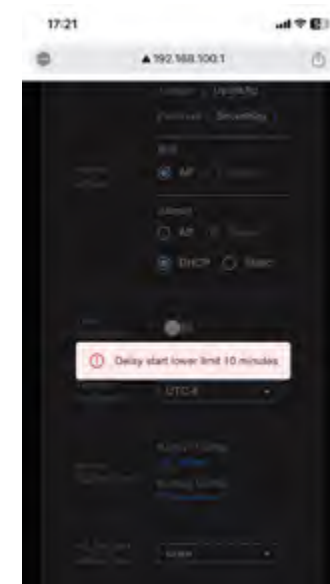

Minimum Delayed Charging Time Limit Error Notification

(7) Time off

1. On the main screen, click "Settings" to enter the system settings.
 - Enter the desired end charging time for the scheduled shutdown.
 - After entering, the indicator light next to the field will turn on.
2. After charging actually starts (when the charging kWh display is not 0), the scheduled shutdown prompt will appear. When the set time is reached, the charging switch will automatically turn off.
3. The input time format is in a 24-hour system, with a maximum setting time of 24 hours and a minimum of 10 minutes

Note: In plug-and-play mode, when using the system webpage to stop charging or set the charging end time, the charging session will only end after the charging plug is removed.

User Interface

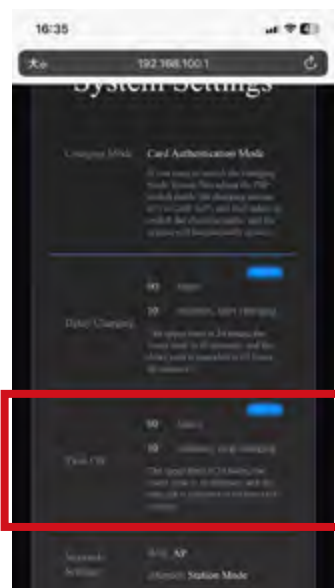

Time off Indicator Light



Charging Operation Area Display



Close Time off

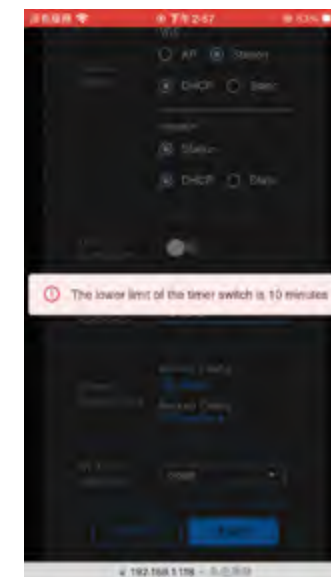

Input Error Indicator

(8) Network Settings

1. Wireless Network

- Change the wireless network to DHCP, save, and the system will automatically reboot.
- Change your phone's WiFi to match the saved WiFi in order to log in.

2. Wired Network

- Add DHCP/Static IP setting for the wired network.
- After entering the settings, click save, and switch to using the wired network to log in.

User Interface

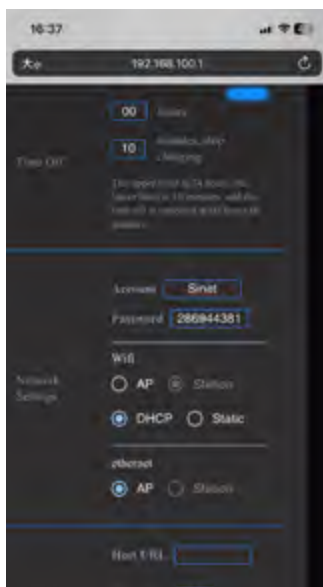

Wireless Network Settings



Wired Network Settings

(9) OCPP Settings

- If a backend connection is required, charging mode selects OCPP mode
- Enter the server URL and the meter value time interval in seconds.
- Please follow the format below:
ws://server IP/...
ws://server URL/...
- After saving, the system will automatically restart.

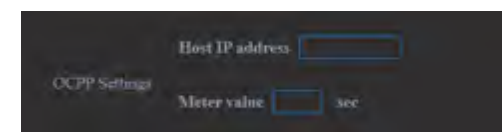
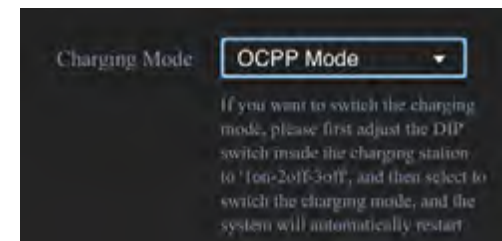

(10) Restore/Backup Config

Restore Config: Upload - Click to upload file.

Backup Config: Download - Click to download file.

User Interface



Restore Config Upload



Backup Config Download

(11) WLAN IP Address Filtering

1. Click on the field, select "Close, Allow,Reject".

2. When selecting Allow or Reject:

- Below, a blank field appears where you can enter the IP address, with a "+" button on the right to add a new field.

- Allow: After saving, only the specified IP addresses can log in.

- Reject: After saving, the specified IP addresses cannot log in

User Interface



WLAN IP Close

Enter Allowed IP Addresses

Enter Rejected IP Addresses

(12) RFID Card Management

1. Card List

- The maximum limit for adding cards is 10.
- When the maximum limit is reached, a prompt will appear: "The card limit is 10, and you have added 10 cards."

2. Add a New Card

- Click on "Add New Card."
- (After listening the charger beep) Please place the card near the charging station's card reader for detection.
- Once the card is successfully read, the card number will appear in the upper left corner.
- A prompt will appear: "Card detection successful. Please enter your card name and click 'Start Adding Card.'"
- After entering the card name, click 'Start Adding Card.'
- The card addition is successful.

User Interface



Card Addition Limit Exceeded Notification



Card Reading

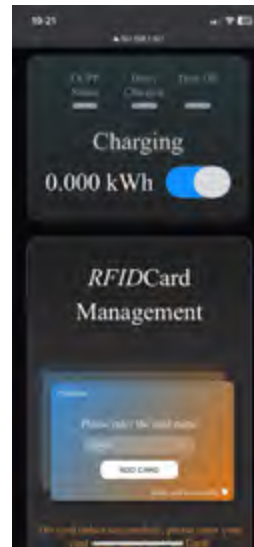

Enter Card Name to Start Adding Card

3. Delete Card

- The RFID card management page displays "Select All Cards and Delete".
- A selectable checkbox appears at the top right corner of each configured card.
- After selecting, you can delete the card.

User Interface

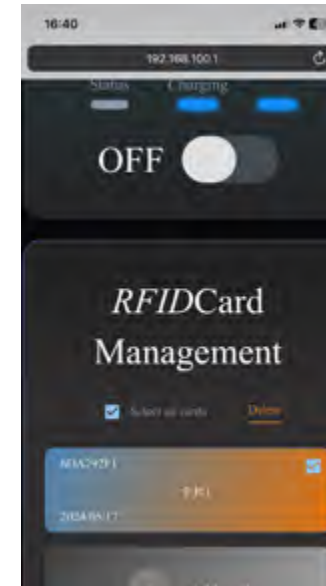

Select all cards

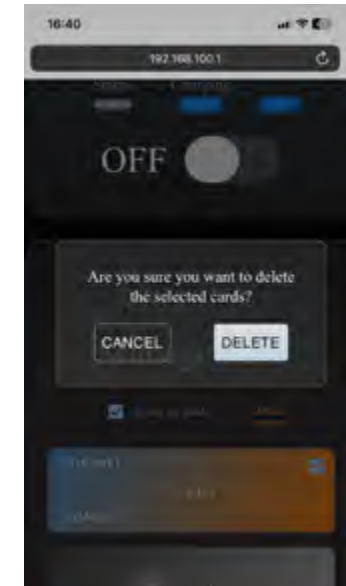

Delete Cards Indicator

(13) Account and Password Settings

1. Change Account

- Click "Change Account" and enter the new account in the input field.
- After entering, click "Confirm Change", and a message will appear indicating the change is complete.

2. Change Password

- Click "Change Password".
- First, enter the old password.
- After entering the new password, re-enter it for confirmation.
- Once done, click "Confirm Change". After logging out, use the newly set password to log in.

User Interface



Account Setting



Change Account

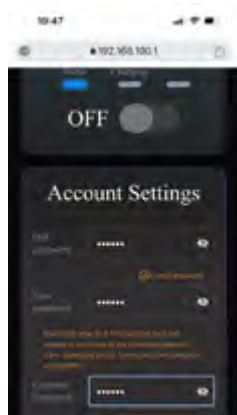

Change Password



Changed Successfully Setting

Troubleshooting Q&A

08

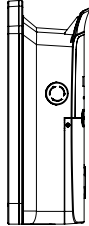
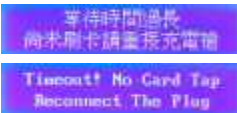
	LED Light [Note 1]	LCM Display Problem [Note 2]	Cause of Problem	Troubleshooting Mode
1	Steady Red Light	<p>“Start Emergency Button”</p> 	<p>Start has already been pressed for emergency button</p> 	<p>After confirming no abnormality on the charger, press the emergency stop switch located on the left side of charger once again to close the release</p>
2	Steady Red Light	<p>“Timeout! No Card Tap Reconnect The Plug” (The information page in Chinese/English displays alternately)</p> 	<p>Card is not swiped after connecting the charging gun and vehicle (approximately 120 seconds)</p>	<p>Please remove the charging gun and reconnect with the vehicle and swipe the card.※</p>

※Only applicable for the user who uses the RFID enable card to enable this AC charger. If the charger does not have the function of enable RFID sensing function, the error page will not be seen.

※When a system reboot is required, the charging station will flash a yellow light three times every 2 seconds in a continuous cycle until the reboot is complete.If the station is in standby mode, charging cannot be initiated. However, if charging is already in progress, it will not be affected and will continue as normal.

※ If the device suddenly displays a white indicator light while in standby mode, it indicates that the system is performing a temporary data clearing operation. This is a normal behavior. This process only occurs after the user has completed charging, either after card swiping or unplugging the connector. It will not occur during charging to ensure the integrity of the charging process. During this operation, the device will be unable to charge and will resume normal function once the process is complete.

※ If you observe abnormal or continuous flashing of the indicator light accompanied by device malfunction, please follow the instructions in the user manual for troubleshooting or contact customer support.

	LED Light [Note 1]	LCM Display Problem [Note 2]	Cause of Problem	Troubleshooting Mode
3	Red Light Flashing for 5 times	"Output current too high"	The charging current exceeds the maximum setting value of output current, charger enters into the protection mode and stop the power supply.	Please turn off the power switch of charger (RCCBs [Note 3]), and then restart the charger, if it continues to occur, please contact with professional for assistance.
4	Red Light Flashing for 5 times	"Malfunction Abnormal Voltage"	If the AC IN voltage is too low or too high, the charger will enter protection mode and stop the power supply.	
5	Red Light Flashing for 9 times	"Malfunction Abnormal Meter" "Meter is abnormal"	Error occurred on the built-in electricity meter of charger.	
6	Red light flashing for 3 times	"Wrong card"	The sensing card used by the charger is damaged or the sensing card used by the charger has not been set.	Please confirm that the enable card used is the unique card certified by the charger. If the card is correct and the card error is still displayed, please contact the professional for assisting in replacing the enable card or re-entering the card number.
7	Red Light Flashing for 5 times	" 温度異常 OTP"	Internal Temperature Abnormality Detected in the Charger.	Please, under dry conditions, switch off and on the residual current circuit breaker inside the power box. This step is to initially rule out whether it is a power supply issue. If the issue persists, please contact a professional for assistance.

※Only applicable for the user who uses the RFID enable card to enable this AC charger. If the charger does not have the function of enable RFID sensing function, the error page will not be seen.

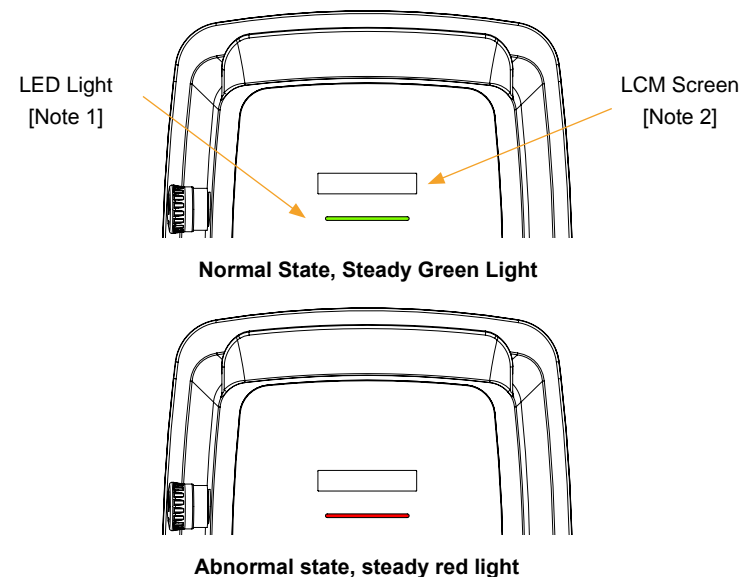

For example: When the abnormality of "Please remove the charging gun due to the card has not been sensed yet" occurs, Red light steady until the issue is resolved.

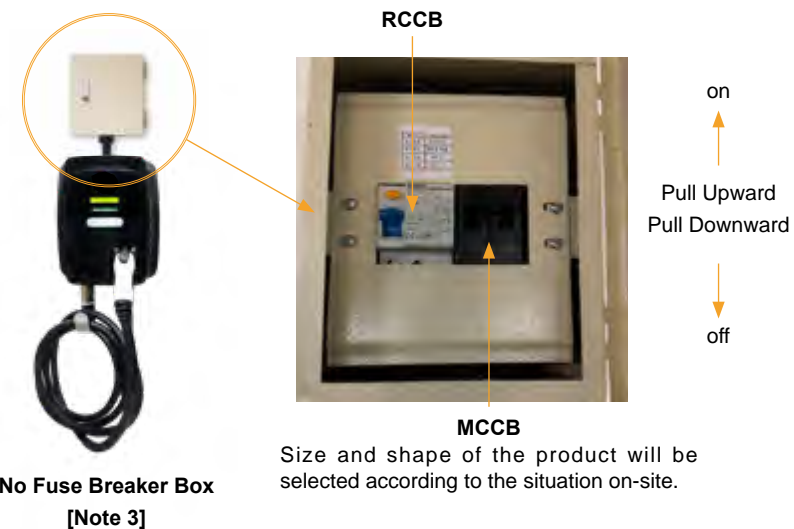

Note: The equipment should be equipped with an appropriate molded case circuit breaker (MCCB) based on the site conditions, and must be installed together with a residual current circuit breaker (RCCB) to ensure electrical safety.

Limited Quality Maintenance of Charging Equipment

09

1. General Terms

- This charger is warranted for 2 years from the date of warranty. The warranty scope includes the charger body and its internal electronic components (except consumables, such as fuses), charging guns, if the warranty stickers have damages, removal trace, or man-made damages, no warranty will be provided even during the warranty period.
- The limited quality maintenance commitment made by Fortune Electric Value Co., Ltd. starts from the date of installation of charger product made by Fortune Electric Value Co., Ltd. for two years ("Quality Warranty Period") to enjoy the quality warranty for the failure presented on the charger itself. This does not include but not limited to the defect or damage caused to the charger of Fortune Electric Value Co., Ltd. due to the following situations, that does not enjoy the limited maintenance warranty:
 - Any direct or indirect damage or malfunction caused due to the normal wear or aging, misuse, abuse, negligence, accident, improper use or storage environment.
 - Fail to follow the operating instruction manual and pre-cautions required by Fortune Electric Value Co., Ltd. for this charger.
 - External factors, including but not limited to collide the charger of Fortune Electric Value Co., Ltd. with objects, the surrounding storage environment or natural disasters (including but not limited to fire, earthquake, flood, lightning and other environmental conditions).
 - General appearance damage, including scratches, dents or cracks.
 - An individual or organization who has not been authorized or licensed by Fortune Electric Value Co., Ltd. to repair, replace or modify the charger of Fortune Electric Value Co., Ltd. in any way, or install or use any parts or accessories.
 - Lacking or performing improper repair or maintenance; and including the use of accessories or parts not provided by Fortune Electric Value Co., Ltd.
 - The device may fail to operate properly due to the use of any adapter or conversion adapter, or charging behaviors that are not compatible with the vehicle.

2. Limitation of Liability

- If the construction/installation of charger is performed by the professional personnel not certified by Fortune Electric Value Co., Ltd. that causes the damage to the equipment, it will not be covered by the warranty scope. If any personal injury or property damage occur, this company will not be liable for any legal responsibility and compensation for damage.
- Regarding the part not covered by the above stated rights, Fortune Electric Value Co., Ltd. does not assume any liability beyond the remedial measures contained in this operating instruction manual, including but not limited to unable to use any product, profit loss, business loss or liability from the data or software loss, demolition, damage or service terms. Except as specifically stated, Fortune Electric Value Co., Ltd. shall not be liable for any derivative, special, indirect, punitive damages (even if Fortune Electric

Value Co., Ltd. has already aware that such damage may occur), or be responsible for claims from any third party. For any liability as related to the purchase of the product, you agree, Fortune Electric Value Co., Ltd. shall not be responsible or liable for paying any compensation in excess of the dollar amount you ordered. In the complaints made by consumer, the scope of responsibility for assisting in clarifying the major casualty or criminal event may be even wider than the damage caused by negligence, under such circumstance, Fortune Electric Value Co., Ltd. will not try to exclude the relevant liability.

3.Maintenance

- If there is dust or dirt on the charger surface, wipe the surface with the dry cloth. Do not use the organic solvent or volatile liquid for wiping to avoid damaging to the charger housing and the risk of fire.
- The qualified electrical professionals at the location may perform the regular test to check if the primary or secondary side contact of the no fuse breaker in the external switch box has any loose or foreign objects.
- When the charger is not used for a long term, the no fuse breaker in the external switch box can be turned off.

- **Model:**
CBDA-X80A

- **Serial Model:**
CBDA-X80-A4,CBDA-X80-A7,CBDA-X70A,CBDA-X50A,CBDA-350A,CBDAX50A-A4,CBDA-X50A-A6,CBDA-X50A-A7,CBDA-X40A,CBDA-X40A-A6,CBDAX32A,CBDA-X32A-A6,CBDA-X24A,CBDA-X24A-A6,CBDA-X16A,CBDA-X16A-A6,CBDA-X70B,CBDA-X70B-A4,CBDA-X70B-A7,CBDA-X50B,CBDA-X40B,CBDAX32B,CBDA-X32B-A4,CBDA-X32B-A7,CBDA-X32B-Y1,CBDA-X24B,CBDA-X16B

Serial Model	Output Current	Power Output (kW)	Charging gun SPEC	KG
CBDA-X80A,CBDA-X80A-A4,CBDA-X80A-A7	80	17.6	SAE J1772	10.5
CBDA-X70A	70	15.4	SAE J1772	10.5
CBDA-X50A,CBDA-X50A-A4,CBDA-X50A-A6,CBDA-X50A-A7,CBDA-350A	50	11	SAE J1772	9.2
CBDA-X40A,CBDA-X40A-A6	40	8.8	SAE J1772	9.2
CBDA-X32A,CBDA-X32A-A6	32	7.04	SAE J1772	9.2
CBDA-X24A,CBDA-X24A-A6	24	5.28	SAE J1772	9.2
CBDA-X16A,CBDA-X16A-A6	16	3.52	SAE J1772	9.2
CBDA-X70B,CBDA-X70B-A4,CBDA-X70B-A7	70	15.4	IEC 62196	10.4
CBDA-X50B	50	11	IEC 62196	10.4
CBDA-X40B	40	8.8	IEC 62196	10.4
CBDA-X32B,CBDA-X32B-A4,CBDA-X32B-A7,CBDA-X32B-Y1	32	7.04	IEC 62196	7.9
CBDA-X24B	24	5.28	IEC 62196	7.9
CBDA-X16B	16	3.52	IEC 62196	7.9

Fortune Electric Value Co., Ltd.

12F, No. 66, Sanchong Rd., Nangang Dist., Taipei City 115602, Taiwan (R.O.C.)
 TEL: (02)2325-3320 FAX: (02)2325-3350
 Official Website: www.evalue.com.tw
 Customer Service Mailbox: service@f-evalue.com

Made in Taiwan

